

# **INDUSTRIAL TUMBLE DRYERS**

**55kg**

**77kg**

**90kg**

**INSTALLATION, OPERATION, MAINTENANCE**

70476501en  
Publication date: Jan 2013



**Installation must conform with local codes or, in the absence of local codes, with:**

**In the U.S.A.**, installation must conform to the latest edition of the American National Standard Z223.1/ NFPA 54 “National Fuel Gas Code” and Standard ANSI/NFPA 70 “National Electric Code.”

**In Canada**, installation must comply with Standards CAN/CSA-B149.1 or Natural Gas and Propane Installation Code and CSA C22.1, latest edition, Canadian Electric Code, Part I.

**In Australia and New Zealand**, installation must comply with the Gas Installations Standard AS/NZS 5601 Part 1: General Installations.



## WARNING

**FOR YOUR SAFETY, the information in this manual must be followed to minimize the risk of fire or explosion or to prevent property damage, personal injury or death.**

W033

- Do not store or use gasoline or other flammable vapors and liquids in the vicinity of this or any other appliance.
- **WHAT TO DO IF YOU SMELL GAS:**
  - Do not try to light any appliance.
  - Do not touch any electrical switch; do not use any phone in your building.
  - Clear the room, building or area of all occupants.
  - Immediately call your gas supplier from a neighbor’s phone. Follow the gas supplier’s instructions.
  - If you cannot reach your gas supplier, call the fire department.
- Installation and service must be performed by a qualified installer, service agency or the gas supplier.

W052

**IMPORTANT:** Information must be obtained from a local gas supplier on instructions to be followed if the user smells gas. These instructions must be posted in a prominent location. Step-by-step instructions of the above safety information must be posted in a prominent location near the tumble dryer for customer use.



## WARNING

To reduce the risk of electric shock, fire, explosion, serious injury or death:

- Disconnect electric power to the tumble dryer before servicing.
- Close gas shut-off valve to gas tumble dryer before servicing.
- Close steam valve to steam tumble dryer before servicing.
- Never start the tumble dryer with any guards/panels removed.
- Whenever ground wires are removed during servicing, these ground wires must be reconnected to ensure that the tumble dryer is properly grounded.

W002R1



## WARNING

- Installation of unit must be performed by a qualified installer.
- Install tumble dryer according to manufacturer's instructions and local codes.
- **DO NOT** install a tumble dryer with flexible plastic venting materials. If flexible metal (foil type) duct is installed, it must be of a specific type identified by the appliance manufacturer as suitable for use with tumble dryer. Refer to section on connecting exhaust system. Flexible venting materials are known to collapse, be easily crushed, and trap lint. These conditions will obstruct tumble dryer airflow and increase the risk of fire.

W752R1

The following information applies to the state of Massachusetts, USA.

- This appliance can only be installed by a Massachusetts licensed plumber or gas fitter.
- This appliance must be installed with a 91 cm (36 inch) long flexible gas connector.
- A "T-Handle" type gas shut-off valve must be installed in the gas supply line to this appliance.
- This appliance must not be installed in a bedroom or bathroom.

# Table of Contents

<b>Introduction</b> .....	5
Model Identification .....	5
Contact Information.....	6
<b>Safety Information</b> .....	7
Important Safety Instructions .....	8
<b>Specifications and Dimensions</b> .....	10
120 Series Tumble Dryer Dimensions and Exhaust Outlet Locations .....	11
170 and 200 Series Tumble Dryer Dimensions and Exhaust Outlet Locations .....	12
Electric and Gas Connection Locations for Gas Models.....	13
Electric and Steam Connection Locations for Steam Models .....	14
Electric Connection Location for Electric Models .....	15
<b>Installation</b> .....	16
Pre-Installation Inspection.....	16
Location Requirements .....	16
Position and Level the Tumble Dryer.....	18
Fire Suppression System.....	18
Check Local Codes and Permits .....	18
Water Requirements.....	18
Water Connections.....	19
Electrical Requirements .....	20
Auxiliary Alarm .....	20
Before Placing Tumble Dryer into Service .....	21
Required for CE Models Only .....	22
Installing CE Gas Drying Tumble Dryer.....	22
General Information .....	22
Orifices.....	23
Properties of CE Gases .....	24
Basic Configuration .....	25
Specific Conversion Procedures .....	25
<b>Exhaust Requirements</b> .....	27
Layout.....	27
Make-Up Air.....	27
Venting .....	27
Individual Venting .....	29
Manifold Venting.....	29
<b>Gas Requirements</b> .....	33
Gas Supply Pipe Sizing and Looping .....	35
High Altitude Orifice Sizing.....	37
<b>Electrical Requirements</b> .....	38
Wiring Diagram .....	38
Grounding Instructions .....	39
For CE Models Only .....	39
Service/Ground Location.....	40
To Connect Electrical Service To The Tumble Dryer.....	42

Jumper Configuration Instructions .....	43
Ferrite Ring Installation .....	43
Electrical Specifications .....	44
For 120 Series Gas and Steam Tumble Dryer Models .....	44
For 120 Series Electric Tumble Dryer Models .....	44
For 170 Series Tumble Dryer Models .....	44
For 200 Series Tumble Dryer Models .....	45
<b>Steam Requirements</b> .....	46
Piping Recommendations .....	46
Installing Steam Trap and Making Condensate	
Return Connections .....	47
Thermal Oil Prep .....	47
<b>Operating Instructions</b> .....	50
Emergency Stop Button On CE Models .....	50
Operating Instructions .....	50
Control Instructions .....	52
Dual Digital Timer Control .....	52
Electronic OPL Micro Control .....	54
LED OPL Control .....	56
Ignition Control Operation for Non-CE Models .....	57
Ignition Control Operation for CE Models .....	58
<b>Adjustments</b> .....	60
Gas Burner Air Shutter .....	60
Airflow Switch .....	60
Loading Door Switch .....	61
Loading Door Catch (120 and 170 Series Models) .....	61
Loading Door Strike (200 Series Models) .....	62
Belt Drive .....	62
<b>Maintenance</b> .....	63
Daily .....	63
Monthly .....	64
Quarterly .....	64
Bi-Annually .....	64
Annually .....	64
Fire Suppression System Maintenance Test .....	65
<b>Before You Call for Service</b> .....	67
<b>Removing Tumble Dryer from Service</b> .....	67
<b>Disposal of Unit</b> .....	68

# Introduction

## Model Identification

Information in this manual is applicable to these models:

	Gas			Steam/Thermal Oil		Electric
<b>120 Series</b>	GA120L	KT120L	LU120N	GT120S	LT120S	GT120E
	GA120N	KT120N	PA120L	GT120T	LT120T	GU120E
	GK120N	KU120L	PA120N	GU120S	LU120S	KT120E
	GT120L	KU120N	PK120N	GU120T	LU120T	KU120E
	GT120N	LA120L	PT120L	KT120S	PT120S	LT120E
	GU120L	LA120N	PT120N	KT120T	PT120T	LU120E
	GU120N	LK120N	PU120L	KU120S	PU120S	PT120E
	KA120L	LT120L	PU120N	KU120T	PU120T	PU120E
	KA120N	LT120N				
	KK120N	LU120L				
<b>170 Series</b>	GA170L	KT170L	LU170N	GT170S	LT170S	Not Applicable
	GA170N	KT170N	PA170L	GT170T	LT170T	
	GK170N	KU170L	PA170N	GU170S	LU170S	
	GT170L	KU170N	PK170N	GU170T	LU170T	
	GT170N	LA170L	PT170L	KT170S	PT170S	
	GU170L	LA170N	PT170N	KT170T	PT170T	
	GU170N	LK170N	PU170L	KU170S	PU170S	
	KA170L	LT170L	PU170N	KU170T	PU170T	
	KA170N	LT170N				
	KK170N	LU170L				
<b>200 Series</b>	LA200L	LU200L	PT200L	LT200S	PT200S	Not Applicable
	LA200N	LU200N	PT200N	LT200T	PT200T	
	LT200L	PA200L	PU200L	LU200S	PU200S	
	LT200N	PA200N	PU200N	LU200T	PU200T	

Includes models with the following control suffixes:

RE – reversing LED OPL

RM – reversing OPL micro

RQ – reversing dual digital timer

## Introduction

### Contact Information

If service is required, contact the nearest Factory Authorized Service Center.

If you are unable to locate an authorized service center or are unsatisfied with the service performed on your unit, contact the source from which you purchased your unit.

When calling or writing about your unit, PLEASE GIVE THE MODEL AND SERIAL NUMBERS. The model and serial numbers are located on the nameplate. The nameplate will be in the location shown in *Figure 1*.

Date Purchased \_\_\_\_\_

Model Number \_\_\_\_\_

Serial Number \_\_\_\_\_

Please include a copy of your bill of sale and any service receipts you have.

	<b>WARNING</b>
<b>To reduce the risk of serious injury or death, DO NOT repair or replace any part of the unit or attempt any servicing unless specifically recommended in the user-maintenance instructions or in published user-repair instructions that you understand and have the skills to carry out.</b>	
<small>W329</small>	

If replacement parts are required, contact the source from where you purchased your tumble dryer.

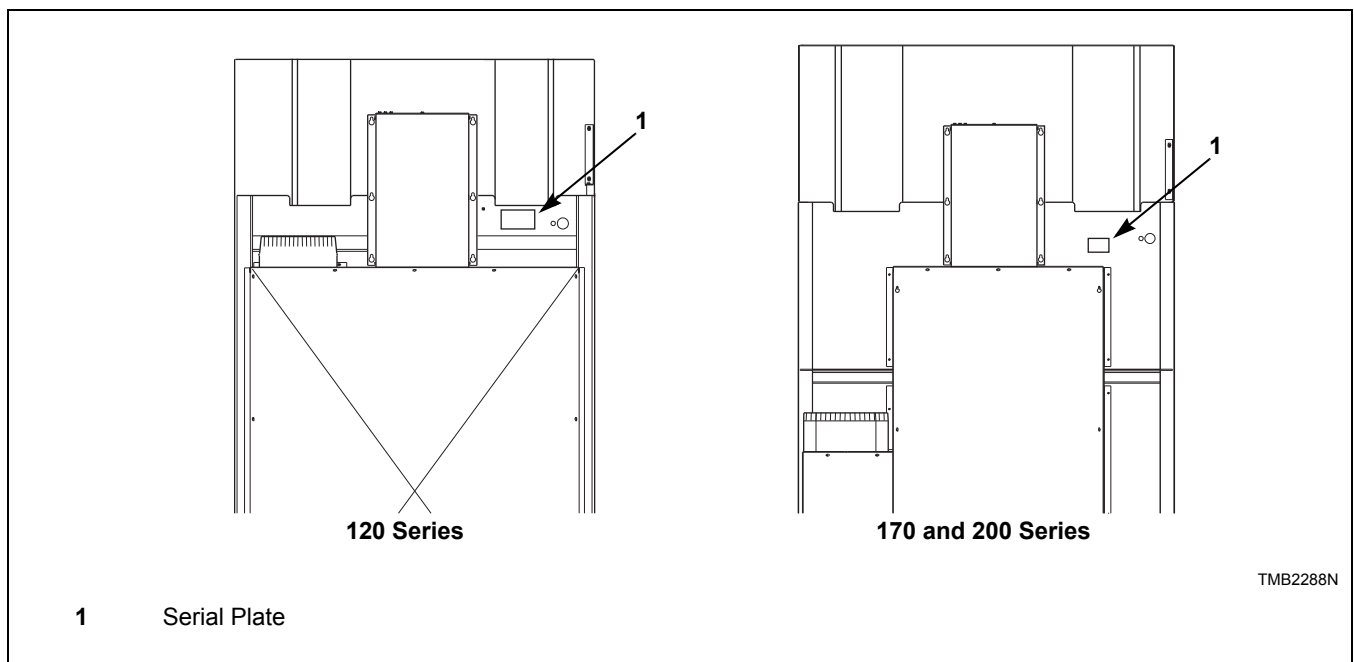



Figure 1



# Safety Information

Precautionary statements (“DANGER,” “WARNING,” and “CAUTION”), followed by specific instructions, are found in this manual and on machine decals. These precautions are intended for the personal safety of the operator, user, servicer, and those maintaining the machine.

	<b>DANGER</b>
Indicates an imminently hazardous situation that, if not avoided, will cause severe personal injury or death.	

	<b>WARNING</b>
Indicates a hazardous situation that, if not avoided, could cause severe personal injury or death.	

	<b>CAUTION</b>
Indicates a hazardous situation that, if not avoided, may cause minor or moderate personal injury or property damage.	

Additional precautionary statements (“IMPORTANT” and “NOTE”) are followed by specific instructions.

**IMPORTANT:** The word “IMPORTANT” is used to inform the reader of specific procedures where minor machine damage will occur if the procedure is not followed.

**NOTE:** The word “NOTE” is used to communicate installation, operation, maintenance or servicing information that is important but not hazard related.

	<b>WARNING</b>
Failure to install, maintain, and/or operate this machine according to manufacturer’s instructions may result in conditions which can produce serious injury, death and/or property damage.	
W051R1	

**NOTE:** The WARNING and IMPORTANT instructions appearing in this manual are not meant to cover all possible conditions and situations that may occur. It must be understood that common sense, caution and carefulness are factors which CANNOT be built into this tumble dryer. These factors MUST BE supplied by the person(s) installing, maintaining or operating the tumble dryer.

Always contact your dealer, distributor, service agent or the manufacturer on any problems or conditions you do not understand.

## Save These Instructions

### Important Safety Instructions

	<b>WARNING</b>
<b>To reduce the risk of fire, electric shock, serious injury or death to persons when using your tumbler, follow these basic precautions.</b>	
<small>W776</small>	

1. Read all instructions before using the tumble dryer.
2. Install the tumble dryer according to the INSTALLATION instructions. Refer to the EARTHING (grounding) instructions for the proper earthing (grounding) of the tumble dryer. All connections for electrical power, earthing (grounding) and gas supply must comply with local codes and be made by licensed personnel when required. It is recommended that the machine be installed by qualified technicians.
3. Do not install or store the tumble dryer where it will be exposed to water and/or weather. The tumble dryer cannot be used in a closed room where the air supply is insufficient. If necessary, ventilation grids must be installed in the doors or the windows.
4. This appliance must not be activated without lint/foam filter.
5. When you perceive a gas odor, immediately switch off the gas supply and ventilate the room. Do not switch on electrical appliances and do not pull electrical switches. Do not use matches or lighters. Do not use a phone in the building. Warn the fitter, and if so desired, the gas company, as soon as possible.
6. To avoid fire and explosion, keep surrounding areas free of flammable and combustible products. Regularly clean the dryer drum and exhaust tube should be cleaned periodically by competent maintenance personnel. Daily remove piled up dust from filter and inside of filter compartment.
7. Do not use or store flammable materials near this appliance.
8. Do not dry articles that have been previously cleaned in, washed in, soaked in or spotted with gasoline or machine oils, vegetable or cooking oils, cleaning waxes or chemicals, dry-cleaning solvents, thinner or other flammable or explosive substances as they give off vapors that could ignite, explode or cause fabric to catch on fire by itself.
9. Do not spray aerosols in the vicinity of this appliance while it is in operation.
10. Items such as foam rubber (latex foam), shower caps, waterproof textiles, rubber backed articles and clothes or pillows filled with foam rubber pads should not be dried in the tumble dryer. Do not use the appliance to dry materials with a low melting temperature (PVC, rubber, etc.).
11. Do not tumble fiberglass curtains and draperies unless the label says it can be done. If they are dried, wipe out the cylinder with a damp cloth to remove particles of fiberglass.
12. Do not allow children on or in the tumble dryer. This appliance is not intended for use by young children or infirm persons without supervision. Young children should be supervised to ensure that they do not play with the appliance.
13. Do not reach into the tumble dryer if the cylinder is revolving.
14. Use tumble dryer only for its intended purpose, drying fabrics. Always follow the fabric care instructions supplied by the textile manufacturer and only use the dryer drum to dry textiles that have been washed in water. Only insert spin-dried linen in the dryer.
15. Always read and follow manufacturer's instructions on packages of laundry and cleaning aids. Heed all warnings or precautions. To reduce the risk of poisoning or chemical burns, keep them out of the reach of children at all times (preferably in a locked cabinet).
16. Do not use fabric softeners or products to eliminate static unless recommended by the manufacturer of the fabric softener or product.
17. Remove laundry immediately after tumble dryer stops.

18. DO NOT operate the tumble dryer if it is smoking, grinding or has missing or broken parts or removed guards or panels. DO NOT tamper with the controls or bypass any safety devices.
19. Tumble dryer will not operate with the loading door open. DO NOT bypass the door safety switch to permit the tumble dryer to operate with the door open. The tumble dryer will stop tumbling when the door is opened. Do not use the tumble dryer if it does not stop tumbling when the door is opened or starts tumbling without pressing or turning the START mechanism. Remove the tumble dryer from use and call for service.
20. Tumble dryer(s) will not operate with lint panel open. DO NOT bypass lint panel safety switch to permit the tumble dryer to operate with the lint panel open.
21. Do not modify this appliance.
22. Always clean the lint filter daily. Keep area around the exhaust opening and adjacent surrounding area free from the accumulation of lint, dust and dirt. The interior of the tumble dryer and the exhaust duct should be cleaned periodically by qualified service personnel.
23. Solvent vapors from dry-cleaning machines create acids when drawn through the heater of the drying unit. These acids are corrosive to the tumble dryer as well as the laundry load being dried. Be sure make-up air is free of solvent vapors.
24. At the end of each working day, close off all main supplies of gas, steam and current.
25. Do not repair or replace any part of the tumble dryer, or attempt any servicing unless specifically recommended in the user-maintenance instructions or in published user-repair instructions that the user understands and has the skills to carry out. ALWAYS disconnect and lockout the electrical power to the tumble dryer before servicing. Disconnect power by shutting off appropriate breaker or fuse.
26. Before the tumble dryer is removed from service or discarded, remove the door to the drying compartment and the door to the lint compartment.
27. Failure to install, maintain, and/or operate this tumble dryer according to the manufacturer's instructions may result in conditions which can produce bodily injury and/or property damage.

**NOTE: The WARNINGS and IMPORTANT SAFETY INSTRUCTIONS appearing in this manual are not meant to cover all possible conditions and situations that may occur. Common sense, caution and care must be exercised when installing, maintaining, or operating the tumble dryer.**

Always contact your dealer, distributor, service agent or the manufacturer on any problems or conditions you do not understand.

# Specifications and Dimensions

Specifications		120 Series	170 Series	200 Series
Noise level measured during operation at operator position of 1 meter (3.3 feet) in front of machine and 1.6 meters (5.2 feet) from floor.		66 dBA	66 dBA	66 dBA
Cylinder Size: mm (Inches)		1118 x 1041 (44 x 41)	1289 x 1080 (50.75 x 42.5)	1289 x 1270 (50.75 x 50)
Cylinder Capacity dry weight: kg (Pounds)		54.4 (120)	77.1 (170)	90.7 (200)
Standard Packaging Weight: kg (Pounds)	Gas and Electric	607 (1338)	756 (1667)	779 (1718)
	Steam	656 (1446)	806 (1776)	825 (1818)
Standard Packaging Shipping Dimensions: mm (Inch)		1232 x 1829 x 2286 (48.5 x 72 x 90)	1473 x 1892 x 2515 (58 x 74.5 x 99)	1422 x 2032 x 2515 (56 x 80 x 99)
Slat Crate Packaging Weight: kg (Pounds)	Gas and Electric	656 (1447)	812 (1791)	848 (1868)
	Steam	702 (1547)	858 (1891)	893 (1968)
Slat Crate Shipping Dimensions: mm (Inch)		1308 x 1880 x 2305 (51.5 x 74 x 90.75)	1549 x 1943 x 2534 (1 x 76.5 x 99.75)	1549 x 2108 x 2565 (61 x 83 x 101)
Cylinder Motor: kW (HP)		0.560 (0.75)	0.560 (0.75)	0.560 (0.75)
Fan Motor: kW (HP)		0.746 (1)	2.238 (3)	2.238 (3)
Air Outlet Diameter: mm (Inches)		254 (10)	300 (12)	300 (12)
Maximum Static Back Pressure: mbar (W.C.I.)		0.8 (0.3)	0.8 (0.3)	0.8 (0.3)
Maximum Airflow: L/sec. (C.F.M)		755 (1600)	1156 (2450)	1156 (2450)
<b>Gas Models</b>				
Net Weight (approximate): kg (Pounds)		578 (1275)	716 (1575)	774 (1707)
Gas Connection		3/4 in. NPT	1 in. NPT	1 in. NPT
Gas Burner Rating: kW (Btu/hr.)		79.13 (270,000)	115.77 (395,000)	124.56 (425,000)
<b>Steam Models</b>				
Net Weight (approximate): kg (Pounds)		624 (1375)	761 (1675)	820 (1807)
Steam Connection		3/4 in. NPT inlet 3/4 in. NPT outlet	3/4 in. NPT inlet 1 in. NPT outlet	3/4 in. NPT inlet 1 in. NPT outlet
Steam Coil Rating at 100 psig: kg/hr. (Btu/hr.) (recommended operating pressure 80-100 psig)		183.1 (405,000)	294.2 (648,000)	294.2 (648,000)
<b>Electric Models</b>				
Heating Element Rating: Kilowatts (kW)		60 kW	Not Applicable	Not Applicable

**NOTE: All machines are shipped with extra nipple to convert to metric thread (from Standard).**

## 120 Series Tumble Dryer Dimensions and Exhaust Outlet Locations

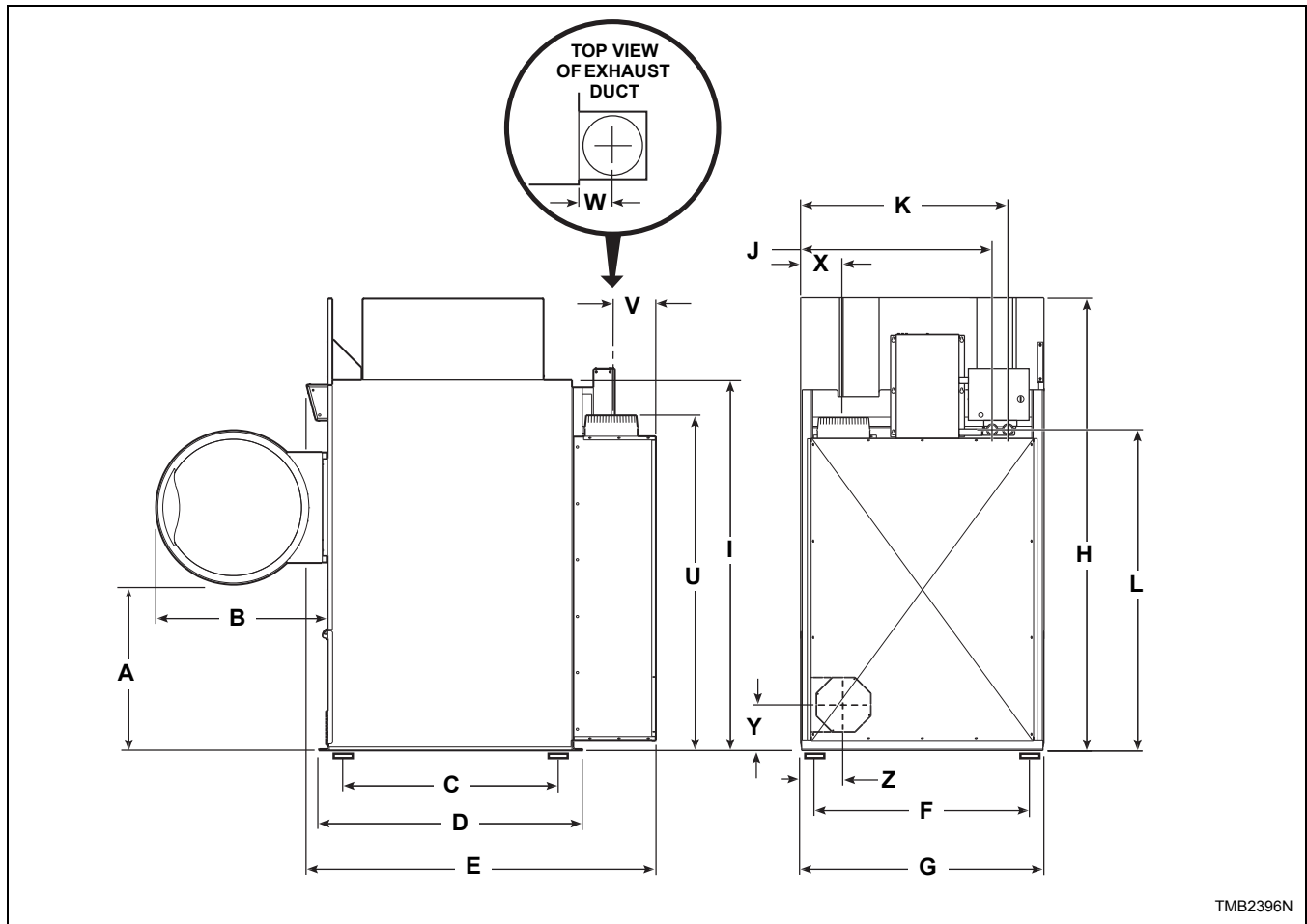

Cabinet Dimensions						
Models	A	B	C	D	E	F
120L/N/E	797 mm (31.38 in.)	826 mm (32.5 in.)	1242 mm (48.91 in.)	1268 mm (49.91 in.)	1725 mm (67.92 in.)	1153 mm (45.38 in.)
120S	797 mm (31.38 in.)	826 mm (32.5 in.)	1242 mm (48.91 in.)	1268 mm (49.91 in.)	1725 mm (67.92 in.)	1153 mm (45.38 in.)
Models	G	H	I	J*	K*	L*
120L/N/E	1178 mm (46.38 in.)	2177 mm. (85.7 in.)	1778 mm. (70 in.)	1057 mm (41.6 in.)	1097 mm (43.2 in.)	1562 mm (61.5 in.)
120S	1178 mm (46.38 in.)	2121 mm (83.5 in.)	1778 mm (70 in.)	1057 mm (41.6 in.)	1097 mm (43.2 in.)	1562 mm (61.5 in.)

\* Fire suppression system optional - may not be on machine.

Refer to *Position and Level the Tumble Dryer* to temporarily reduce the heights of these models.

Exhaust Outlet Dimensions and Locations						
Models	U	V	W	X	Y	Z
120L/N/E	1612 mm (63.45 in.)	214 mm (8.44 in.)	127 mm (5 in.)	208 mm (8.18 in.)	173 mm (6.82 in.)	208 mm (8.18 in.)
120S	1542 mm (60.7 in.)	214 mm (8.44 in.)	127 mm (5 in.)	208 mm (8.18 in.)	173 mm (6.82 in.)	208 mm (8.18 in.)

# 170 and 200 Series Tumble Dryer Dimensions and Exhaust Outlet Locations

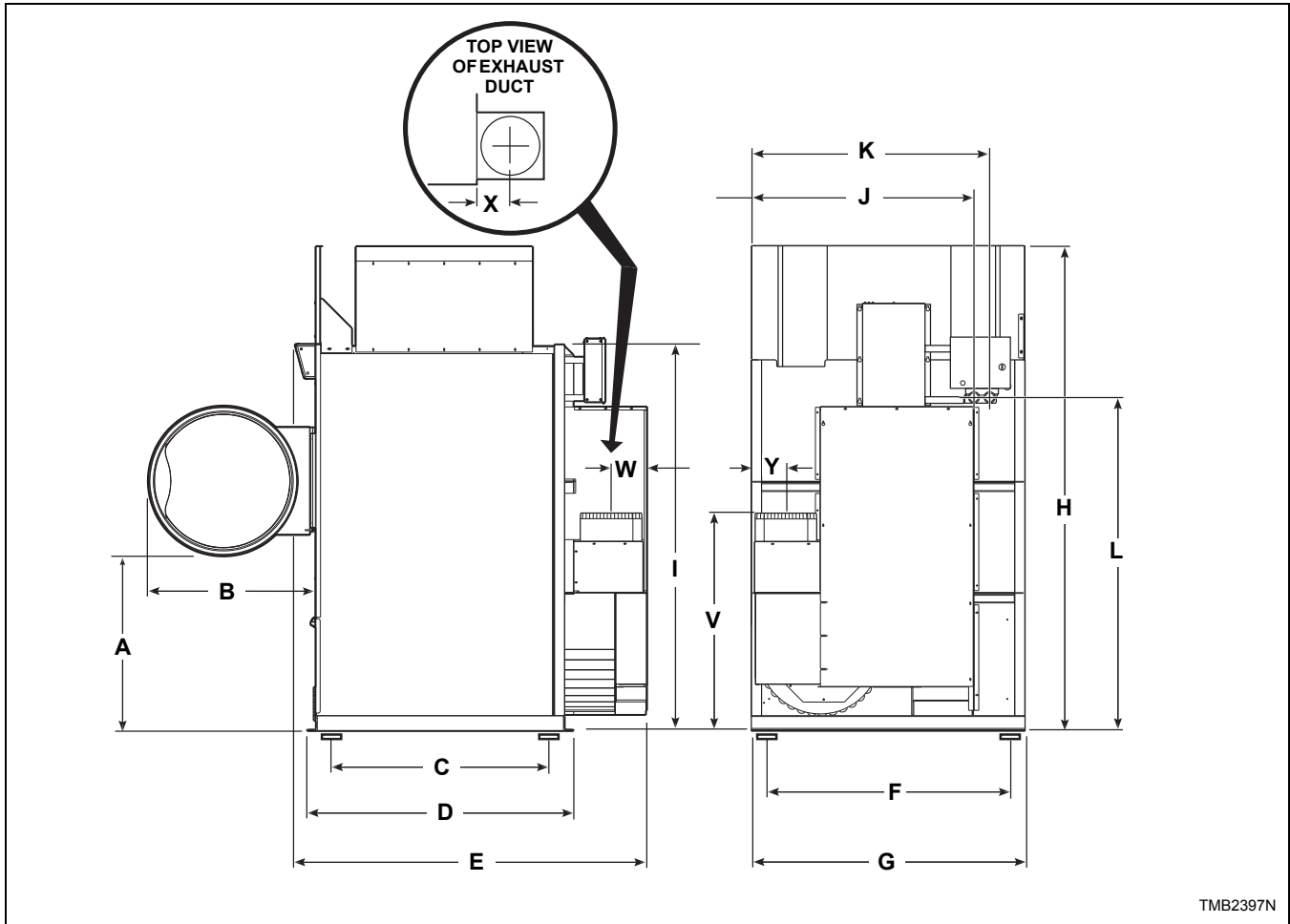

TMB2397N

Cabinet Dimensions						
Models	A	B	C	D	E	F
170 L/N/S	860 mm (33.86 in.)	826 mm (32.5 in.)	1289 mm (50.75 in.)	1314 mm (51.75 in.)	1749 mm (68.85 in.)	1324 mm (52.12 in.)
200 L/N/S	815 mm (32.1 in.)	904 mm (35.6 in.)	1473 mm (58 in.)	1505 mm (59.25 in.)	1939 mm (76.35 in.)	1324 mm (52.12 in.)
Models	G	H	I	J*	K*	L*
170 L/N/S	1349 mm (53.12 in.)	2388 mm (94 in.)	1908 mm (75.12 in.)	1241 mm (48.86 in.)	1281 mm (50.45 in.)	1588 mm (62.5 in.)
200 L/N/S	1349 mm (53.12 in.)	2388 mm (94 in.)	1908 mm (75.12 in.)	1241 mm (48.86 in.)	1281 mm (50.45 in.)	1588 mm (62.5 in.)

\* Fire suppression system optional - may not be on machine.

Refer to **Position and Level the Tumble Dryer** to temporarily reduce the heights of these models.

Exhaust Outlet Dimensions and Locations				
Models	U	V	W	X
170 L/N/S	1076 mm (42.38 in.)	171 mm (6.75 in.)	152 mm (6 in.)	178 mm (7 in.)
200 L/N/S	1076 mm (42.38 in.)	171 mm (6.75 in.)	152 mm (6 in.)	178 mm (7 in.)

## Electric and Gas Connection Locations for Gas Models

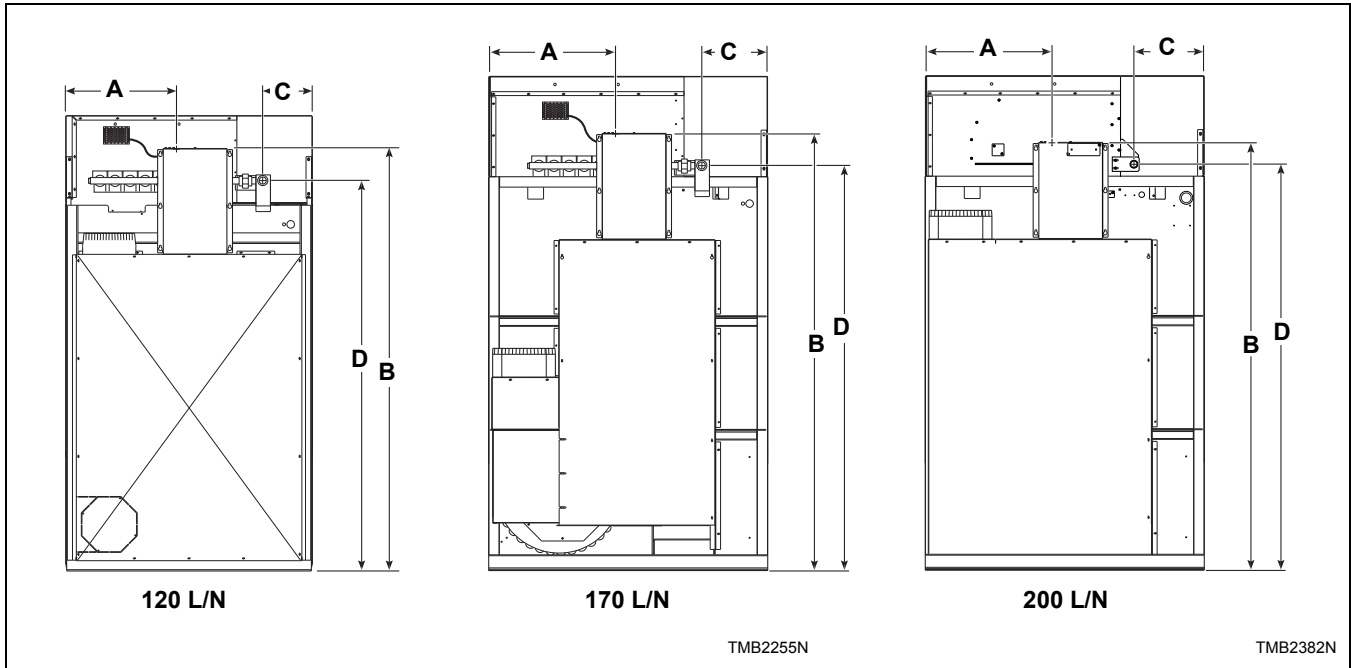

Models	Electrical Connection		Gas Connection		
	A	B	C	D	Diameter
<b>120L/N</b>	466 mm (18.34 in.)	1977 mm (77.84 in.)	318 mm (12.5 in.)	1791 mm (70.5 in.)	3/4 in. NPT
<b>170L/N</b>	533 mm (21 in.)	2057 mm (81 in.)	377 mm (14.85 in.)	1966 mm (77.4 in.)	1 in. NPT
<b>200L/N</b>	533 mm (21 in.)	2057 mm (81 in.)	348 mm (13.7 in.)	1966 mm (77.4 in.)	1 in. NPT

## Electric and Steam Connection Locations for Steam Models

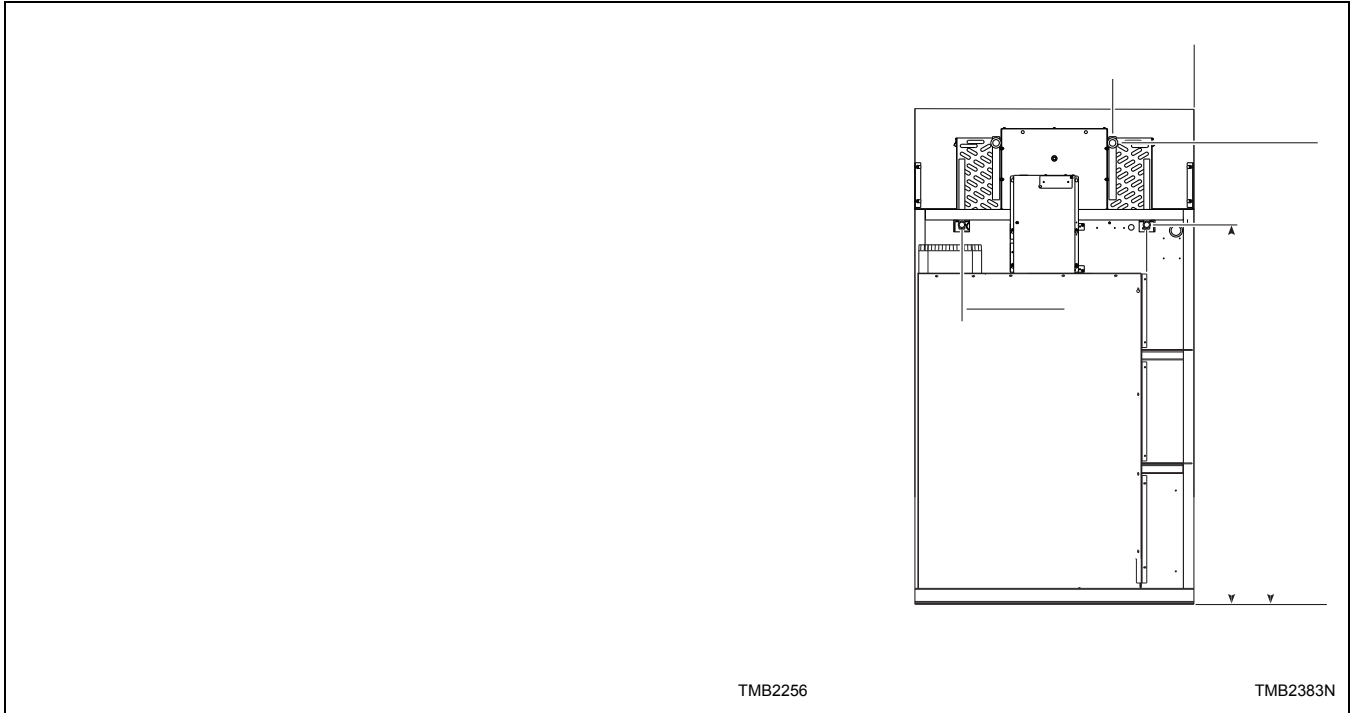





# Installation

## Pre-Installation Inspection

Upon delivery, visually inspect the crate, carton and parts for any visible shipping damage. If the crate, carton, or cover is damaged or signs of possible damage are evident, have the carrier note the condition on the shipping papers before the shipping receipt is signed, or advise the carrier of the condition as soon as it is discovered.

Remove the crate and protective cover as soon as possible and check the items listed on the packing list. Advise the carrier of any damaged or missing articles as soon as possible. A written claim should be filed with the carrier immediately if articles are damaged or missing.

**IMPORTANT: Remove the shipping tape from the two back draft dampers located in the exhaust outlet.**

**IMPORTANT: Warranty is void unless tumble dryer is installed according to instructions in this manual. Installation should comply with minimum specifications and requirements detailed in this manual and applicable local gas fitting regulations, municipal building codes, water supply regulations, electrical wiring regulations, and any other relevant statutory regulations. Due to varied requirements, applicable local codes should be thoroughly understood and all pre-installation work arranged for accordingly.**

Materials Required (Obtain Locally)	
<b>All Models</b>	One Single Pole fused disconnect switch or circuit breaker on 1 Phase models. Circuit breaker on 3 Phase models.
<b>Gas Models</b>	One gas shut-off valve for gas service line to each tumble dryer.
<b>Steam Models</b>	One steam shut-off valve for steam service line to be connected upstream of solenoid steam valve. Two steam shut-off valves for each condensate return line. Flexible steam hoses with a 8.79 kg/sq. cm (125 psig [pounds per square inch gauge]) working pressure for connecting steam coils. Refer to <i>Figure 19</i> and <i>Figure 20</i> for sizing and connection configurations. Two steam traps for steam coil outlets to condensate return line. Optional – Two vacuum breakers for condensate return lines.

**IMPORTANT: 3 Phase Only – Each tumble dryer must be connected to its own individual branch circuit breaker, not fuses, to avoid the possibility of “single phasing” and causing premature failure of the motor(s).**

## Location Requirements

The tumble dryer must be installed on a level floor. Floor covering materials such as carpeting or tile should be removed.

To assure compliance, consult local building code requirements. The tumble dryer must not be installed or stored in area where it will be exposed to water and/or weather.

**IMPORTANT: DO NOT block the airflow at the rear of the tumble dryer with laundry or other articles. Doing so would prevent adequate air supply to the combustion chamber of the tumble dryer.**

A typical tumble dryer enclosure is shown in *Figure 2*.

**IMPORTANT: Install tumble dryers with sufficient clearance for servicing and operation, refer to *Figure 2*.**



## WARNING

To reduce the risk of severe injury, clearance of tumbler cabinet from combustible construction must conform to the minimum clearances, and/or local codes and ordinances.

W770

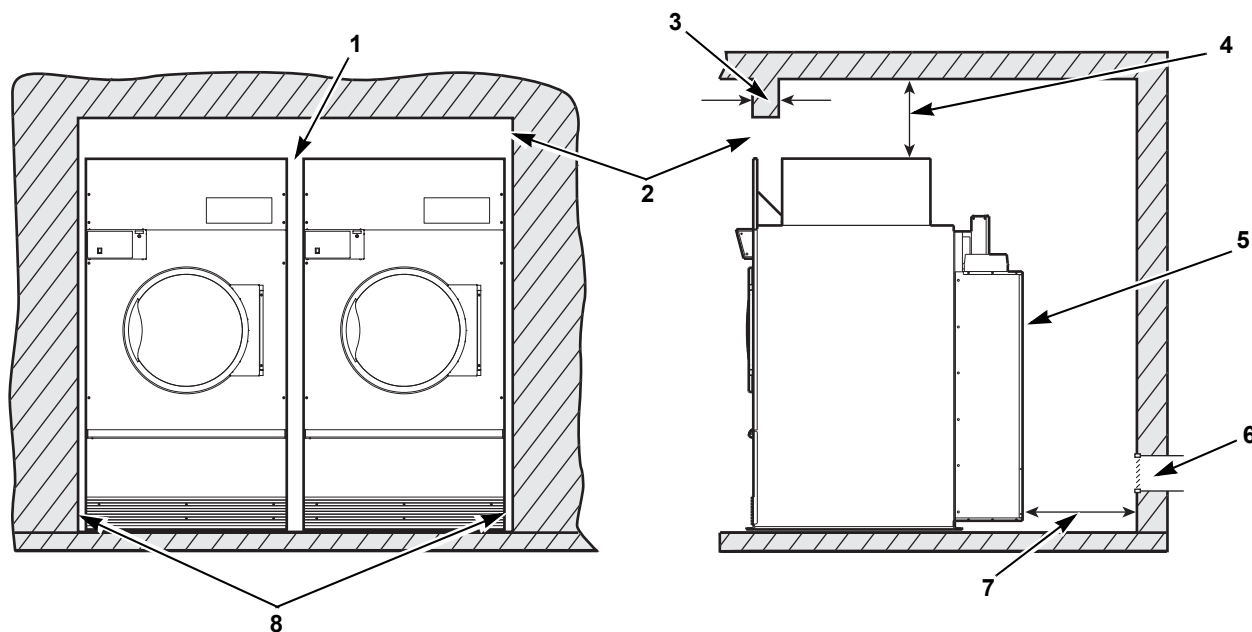

TMB2020N

**NOTE: Shaded areas indicate adjacent structure.**

- 1 13 mm (0.5 in.) recommended between machines for removal or installation
- 2 Allow 51-102 mm (2-4 in.) opening at top of machine to aid in removal or installation. A removable trim piece may be used to conceal the opening; zero clearance allowed for trim
- 3 102 mm (4 in.) maximum header thickness
- 4 Minimum clearance permitted for remainder: Gas and Electric 102 mm (4 in.), Steam 305 mm (12 in.)
- 5 Guard
- 6 Provision for make-up air
- 7 610 mm (24 in.) minimum, 914 mm (36 in.) recommended for maintenance purposes
- 8 6 mm (0.25 in.) recommended for removal or installation purposes, zero clearance allowed

Figure 2

### Position and Level the Tumble Dryer

The tumble dryer may be moved with or without the skid. To remove the skid, unscrew the four shipping bolts, and discard them.

To fit a 170 and 200 series tumble dryer (with shipping skid) through a 2.43 meters (8 foot) high door, you must remove the front access panel. The upper 76 mm (3 inches) of the stove must also be removed on 170 series gas tumble dryers. Removing the entire gas or steam heater assembly and the shipping skid, will reduce the height of the 120 series tumble dryer to 1778 mm (70 inches), and the 170 and 200 series tumble dryer to 1905 mm (75 inches).

Level the tumble dryer to within 3 mm (0.125 inch) from front-to-rear (level on cylinder rib), and side-to-side (level on top panel). Shim under corners to level and stabilize unit. Tumble dryer must not rock.

### Fire Suppression System

#### Check Local Codes and Permits

Call your local water company or the proper municipal authority for information regarding local codes.

**IMPORTANT: It is your responsibility to have ALL plumbing connections made by a qualified professional to assure that the plumbing is adequate and conforms to local, state, and federal regulations or codes.**

**IMPORTANT: It is the installation or owner's responsibility to see that the necessary or required water, water pressure, pipe size, or connections are provided. Manufacturer assumes no responsibility if the fire suppression system is not connected, installed, or maintained properly.**

#### Water Requirements

**IMPORTANT: Water must be supplied to the fire suppression system, or the fire suppression system will not operate as intended.**

Connection point to the electric water solenoid valve is a 19 mm (3/4 inch) hose. The fire suppression system equipped tumble dryer must be supplied with a minimum water pipe size of 12.7 mm (1/2 inch) and be provided with a minimum of 138 kPa (20 psi) and a maximum of 827 kPa (120 psi) of pressure at all times. Flow rate must be no less than, but approximately 57 liters (15 gallons) per minute.

**NOTE: Water pressure under 138 kPa (20 psi) will cause low flow and water leakage at water solenoid valve.**

If the rear of the tumble dryer or the water supply is located in an area where it will be exposed to cold/freezing temperatures, provisions must be made to protect these water lines from freezing.

**IMPORTANT: Temperature of the water supply must be kept between 4.4°C and 48.9°C (40°F and 120°F). If water in the supply line or water solenoid valve freezes, the fire suppression system will not operate.**

**IMPORTANT:** If temperature sensors inside the tumble dryer register a temperature below 4.4°C (40°F), the fire suppression system control will lock out. This feature protects against operation of the tumble dryer with a possible frozen water supply. Only when the temperature sensors register a temperature above 4.4°C (40°F) will the machine reset for operation.

**IMPORTANT:** Flexible supply line/coupling must be used. Solenoid valve failure due to hard plumbing connections will void the warranty. It is recommended that a filter or strainer be installed in the water supply line.

### Water Connections

Two hoses and a Y-valve are provided with the tumble dryer to allow for connection of water supply to tumble dryer. The water connections are made to the bushings of the water solenoid valve, located on the rear of the tumble dryer. The Y-valve provides a single female hose connection (Standard US 3/4-11 1/2 NH thread). Refer to *Figure 3* and *Figure 4*.

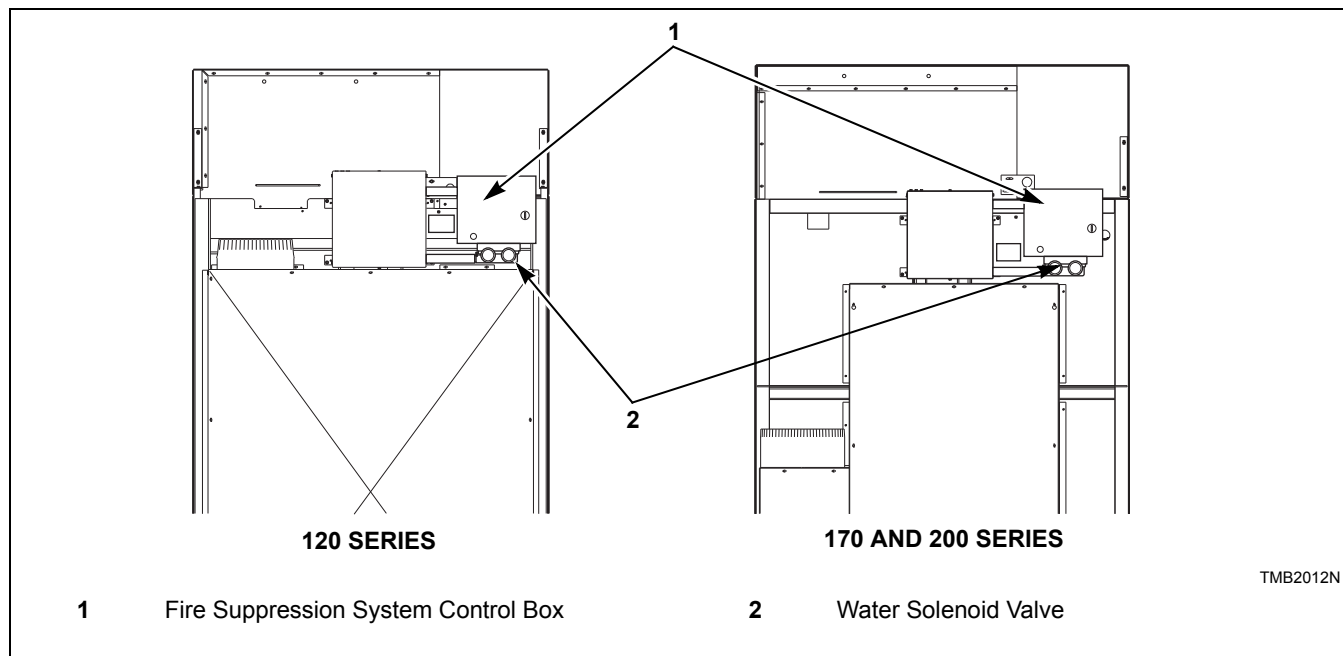

Figure 3

To connect the two hoses (supplied with tumble dryer), insert rubber washers (from literature pack) in water inlet hose couplings. Refer to *Figure 4*.

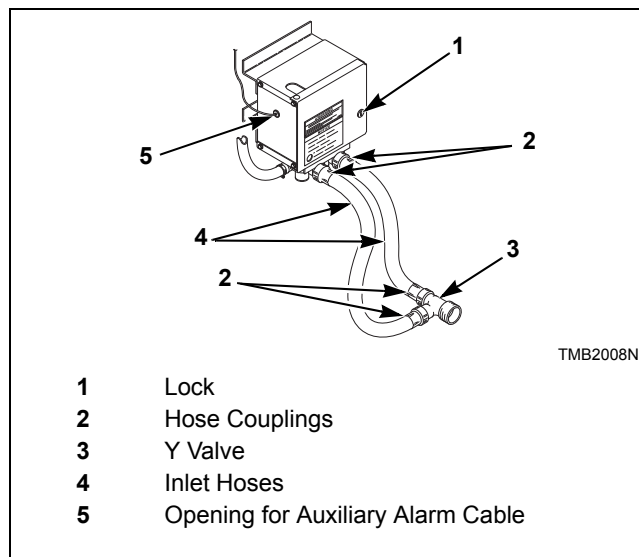

Figure 4

## Installation

Connect inlet hoses to water supply. Flush the lines for approximately two minutes to remove any foreign materials that could clog the screens in the water mixing valve. This is especially important when installing a tumble dryer in a newly constructed or renovated building. Then connect the hoses to the Y-valve; connect the Y-valve to the connections at the rear of the tumble dryer.

**IMPORTANT: Thread hose couplings onto valve connections finger tight, then turn 1/4 turn with pliers. Do not cross thread or overtighten couplings.**

**IMPORTANT: Hoses and other natural rubber parts deteriorate after extended use. Hoses may develop cracks, blisters or material wear from the temperature and constant high pressure they are subjected to.**

All hoses should be checked on a yearly basis for any visible signs of deterioration. Any hose showing the signs of deterioration listed above should be replaced immediately. All hoses should be replaced every five years.

**NOTE: Longer inlet hoses are available (as optional equipment at extra cost) if the hoses supplied with the tumble dryer are not long enough for installation. Order hoses as follows:**

Part No. 20617 Inlet hose 2.44 m (8 feet)  
Part No. 20618 Inlet hose 3.05 m (10 feet)

**NOTE: Replacement outlet hoses are available (at extra cost). Order 44073302 Hose, 53 cm (21 in.) for 120 series and 44073303, 79 cm (31 in.) for 170 and 200 series.**

## Electrical Requirements

	<b>WARNING</b>
<b>Electrical power must be provided to tumbler at all times. The fire suppression system will be inoperative if the main electrical power supply is disconnected.</b>	
<small>W690</small>	

No independent external power source or supply connection is necessary. Power to operate the 24 Volt fire suppression system is from the rear junction/contacter box.

## Auxiliary Alarm

The fire suppression system provides an auxiliary output signal when the system is activated. During tumble dryer installation, you have the option to connect a separate alarm system to this auxiliary output. Potential uses of the auxiliary output include, but are not limited to: (1) sounds an alarm, (2) activates a building sprinkler system, (3) notifies a fire department, etc. Use of the auxiliary output is not required for the fire suppression system to operate, but may be used for additional protection.

The connection to the auxiliary output is made through the FS-1 and FS-2 fast-on connections inside the fire suppression control box. Refer to *Figure 5*. The relay is rated for 24 VAC, 5.2 Amp, sealed current.

**NOTE: The auxiliary output is activated during fire suppression system maintenance test sequence. Consider this fact prior to your system test every three months. (Example: If the external system uses the auxiliary output to call the fire department, inform the fire department before and after the fire suppression system maintenance test.)**

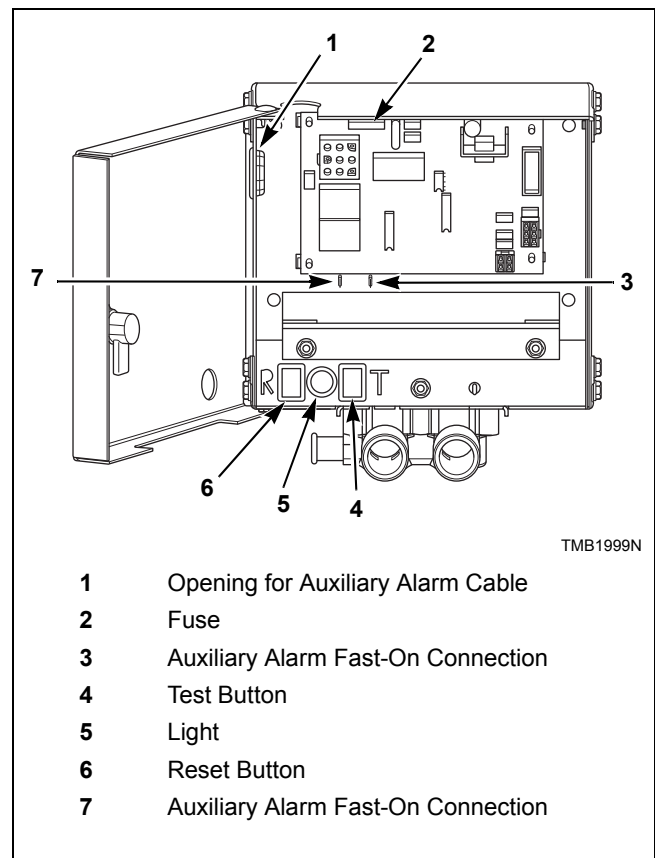

Figure 5

## Before Placing Tumble Dryer into Service

1. Remove or open all panels and check accessible bolts, nuts, screws, terminals and fittings for tightness.
2. Check V-belt tension and adjust if necessary. Refer to *Adjustments* section.
3. Replace all panels and guards.
4. Turn on electrical supply to tumble dryer.
5. Open the supply valve for gas or steam heated tumble dryers.
6. After performing the previous checks, start the tumble dryer by pressing START. (Refer to the *Operating Section* for detailed instructions.) Release the start button and open the loading door. The cylinder should stop rotating within seven seconds after the door is opened.
7. **Gas Tumble Dryers:** Start the tumble dryer and check the burner flame. Adjust the air inlet shutter as required. Refer to *Adjustments* section.

**IMPORTANT:** The electronic ignition system will attempt to light the gas by sparking for the “trial for ignition” period. If gas does not ignite within this period, the ignition control will go into a safety lockout and the valve will no longer open until the control is reset. It may be necessary to retry several times to bleed air from the gas lines. To reset, open and close the loading door and restart tumble dryer.

Location	Prepurge Time (seconds)	Trial for Ignition (seconds)	Reset Lockout Condition By:
Australia	18	10	Press and hold reset button on junction box until light goes out.
All others	1-3	10	Open loading door.

Table 1

If lockout condition persists, check that the manual gas shut-off valve is in the ON position and that the gas service is properly connected. If condition still persists, remove tumble dryer from service.

8. Load the cylinder with a full load of clean rags and run to remove oil or dirt from cylinder.
9. Check the airflow switch operation by opening the lint panel; be sure to remove shipping tape from airflow switch prior to operation. Temporarily tape down the lint panel safety switch located behind the upper left corner of the lint panel. The heating systems should shut off when the lint panel is opened a maximum of 152.4 mm (6 inches). The airflow switch operation may be affected by lack of make-up air or an obstruction in the exhaust duct. These should be checked; if there is a problem, contact an authorized service person.

	<b>WARNING</b>
<p><b>Do not operate tumble dryer if airflow switch is faulty. An explosive gas mixture could collect in tumble dryer if airflow switch does not operate properly.</b></p>	
W407R1	

10. Wipe out the cylinder using an all-purpose cleaner or detergent and water solution. Refer to *Figure 6*.

**IMPORTANT:** The use of chlorine bleach for removing any discoloration should be avoided because bleach could damage the finish.

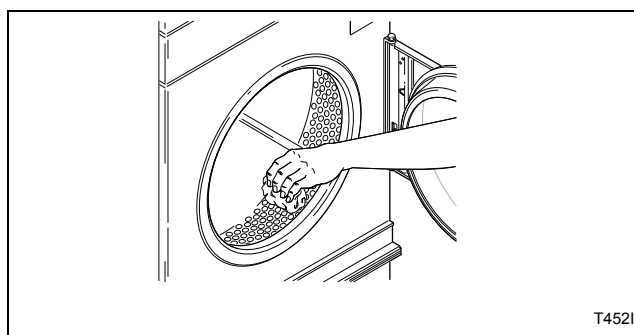

Figure 6

If the tumble dryer does not meet ANY of the listed requirements, remove tumble dryer from use. Refer to *Removing Tumble Dryer from Service* section.

## Installation

### Required for CE Models Only

Once machine is installed, please be sure to complete the following items:

- Review and verify machine operation with customer.
- Leave all literature and a signed Declaration of Conformity with customer.
- Review machine warranty information with customer.
- Apply warning sticker on front panel of machine, in language appropriate to country of sale (included in literature packet).

## Installing CE Gas Drying Tumble Dryer

### General Information

This information is to be used when installing gas tumble dryers in countries and/or on gases different than the machine's factory configuration. Tumble dryers are supplied from the factory for operation on Natural Gas 8914 kCal/m<sup>3</sup> (1000 Btu/cu. ft.), or L.P. Gas 22,250 kCal/m<sup>3</sup> (2500 Btu/cu. ft.), with natural gas group H/E, designation G20 and L.P. gas group B/P, designation G30. To install machines in any other country, or on any other gas, requires some level of modification.

Machines are built in two different configurations:

- **Natural Gas** – regulated/governor
- **Liquefied Petroleum (L.P.) Gas** – not regulated/no governor

Serial plates supplied from the factory are configured for GB/IE/PT/ES/IT/GR/LU/CH/BE. These instructions pertain to the situations when the country of use or gas supply is different than that on the serial plate.

These instructions are only valid if the following country code is on the appliance: GB/IE/PT/ES/IT/GR/LU/CH/BE. If this code is not present on the appliance, it is necessary to refer to the technical instructions which will provide the necessary information concerning the modification of the appliance to the condition of use for the country.

Before installation, check that the local distribution conditions, nature of gas and pressure, and the adjustment of the appliance are compatible.

*Table 2* describes the different gases that are available in different CE countries, and how the machines need to be configured to operate with those gases. In the CE, there are Natural Gas configurations that do not allow for machine regulation and L.P. Gas configurations that must be regulated. For L.P. Gas, third family B/P at 50 mbar, order Regulated Natural Gas machines and convert according to *Table 2*.



## Orifices

Gas Type	Gas Family	Group	Gas Designation	Supply Pressure, mbar	Manifold Pressure		Capacity/ Model	Orifice Diameter (mm)	Orifice Part Number	Quantity
					mbar	in. wc				
Natural Gas	Second	I <sub>2H(E)</sub>	G20	20 / 25	8.9	3.57	120	4.3	M402988	3
							170	4.7	M411510	4
							200	4.8	M411372	4
		I <sub>2L</sub>	G25	25	12.6	5.06	120	4.3	M411373	3
							170	4.7	M411510	4
							200	4.8	M411372	4
		I <sub>2E+</sub>	G20	20	Unregulated	Unregulated	120	3.6	M401014	3
							170	3.8	M402997	4
							200	3.9	M401020	4
LP	Third	I <sub>3B/P</sub>	G30	28 / 30	Unregulated	Unregulated	120	2.5	M406361	3
							170	3.0	M401017	3
							200	3.1	70070903	3
		I <sub>3+/3P</sub>	G30 / G31	28 / 37	Unregulated	Unregulated	120	2.5	M406361	3
							170	3.0	M401017	3
							200	3.1	70070903	3

Table 2

## Installation

### Properties of CE Gases

Gas Type	Gas Family	Group	Gas Description	Gas Designation	Wi		Hi		Ws		Hs		d Density
					Wobbe Index (Net)		Heating Value (Net)		Wobbe Index (Gross)		Heating Value (Gross)		
					MJ/m <sup>3</sup>	Btu/ft <sup>3</sup>	MJ/m <sup>3</sup>	Btu/ft <sup>3</sup>	MJ/m <sup>3</sup>	Btu/ft <sup>3</sup>	MJ/m <sup>3</sup>	Btu/ft <sup>3</sup>	
Natural Gas	Second	I <sub>2H,E</sub>	Not Applicable	G20	45.67	1226	34.02	913	50.72	1362	37.78	1014	0.555
		I <sub>2E+</sub>	2H										
		I <sub>2L</sub>	Not Applicable	G25	37.38	1004	29.25	785	41.52	1115	32.49	872	
		I <sub>2E+</sub>	2L										
LP	Third	I <sub>3B/P</sub>	Not Applicable	G30	80.58	2164	116.09	3117	87.33	2345	125.81	3378	2.075
		I <sub>3+</sub>	Pure Butane										
		I <sub>3+</sub>	Pure Propane	G31	70.69	1898	88	2363	76.83	2063	95.65	2568	
		I <sub>3P</sub>	LPG with Propane										

Table 3

## Basic Configuration

1. Determine the necessary conversion operations to convert from the factory-supplied configuration to the desired configuration.
2. Perform the conversions required so the machine is properly configured for the desired country and gas (refer to *Specific Conversion Procedures* section):
  - How to Convert Gas Valve from Regulated to Unregulated
  - How to Change Burner Orifice Size
  - How to Adjust Gas Valve Governor/Regulator
3. If applicable, peel off the appropriate country sticker (included with machine) and apply it to the serial plate over the existing country information.
4. If applicable, peel off the appropriate conversion sticker (included with machine) and apply it to the serial plate over the “ADJUSTED FOR \_\_\_\_\_ GAS: \_\_\_\_\_” information.
5. Commission tumble dryer for use.

	<b>WARNING</b>
<p><b>When converting the tumble dryer to a different gas or pressure, first verify that the supply inlet pressure is equipped with a pressure regulator (located ahead of the tumble dryer) that will maintain the gas supply at the inlet pressure specified.</b></p>	
W430R1	

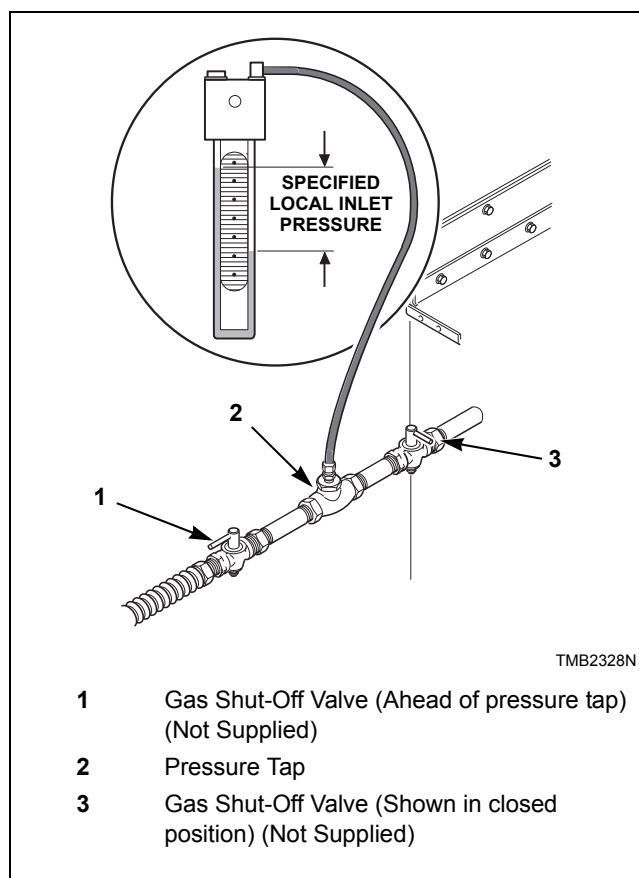

Figure 7

## Specific Conversion Procedures

### *How to Convert Gas Valve from Regulated to Unregulated*

**NOTE: Conversion from regulated to unregulated is only needed when regulated tumble dryers were ordered, but unregulated tumble dryers were needed.**

1. Disconnect electrical power from tumble dryer. Close gas shut-off valve to tumble dryer. Refer to *Figure 7*.
2. Follow instructions in Conversion Kit, Part No. M400763 (Johnson Part No. Y71AA-5C).

**NOTE: This kit does not contain any burner orifices.**

3. Replace burner orifice(s) as per *Table 2*.
4. Commission tumble dryer for use.

## Installation

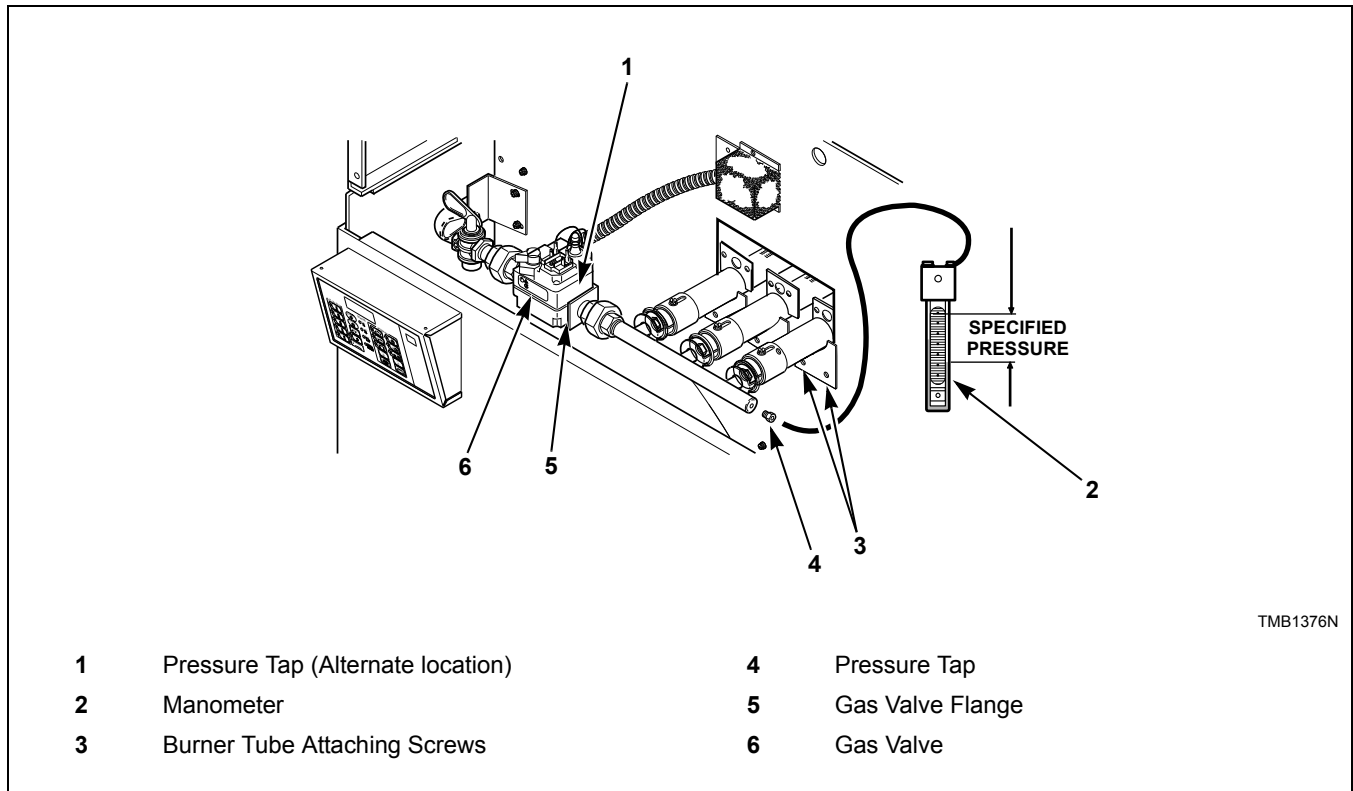

Figure 8

### How to Change Burner Orifice Size

1. Disconnect electrical power from tumble dryer. Close gas shut-off valve to tumble dryer. Refer to *Figure 7*.
2. Remove gas valve:
 

Remove the burner orifice(s) from the spud holder. When converting from Natural Gas to L.P. Gas, the left-most burner and orifice (viewed from front) must be removed. In place of the removed orifice, a blank orifice (Part No. M400995) and a Burner Opening Cover (Part No. M413099) must be installed.
3. Install the new, correct burner orifice(s). Refer to *Figure 9* and *Table 2*. Torque each to 9 - 10 Nm.
4. Reinstall spud holder assembly to gas valve, making certain burner orifice(s) are in line with burner tube opening. Refer to *Figure 9*.
5. Commission tumble dryer for use.

**NOTE: Blank burner orifices are Part No. M400995.**

### How to Adjust Gas Valve Governor/Regulator

1. Check gas burner orifice (manifold) pressure as follows. Refer to *Figure 8*.
2. Remove screw plug from pressure tap.
3. Connect a "U"-tube manometer (or similar pressure gauge) to the burner orifice (manifold) pressure tap.
4. Start tumble dryer and note pressure once flame is burning. Remove regulator cap and adjust regulator screw until the burner orifice pressure per applicable table is achieved. Replace regulator cap. Refer to *Figure 8*.
5. Commission tumble dryer for use.

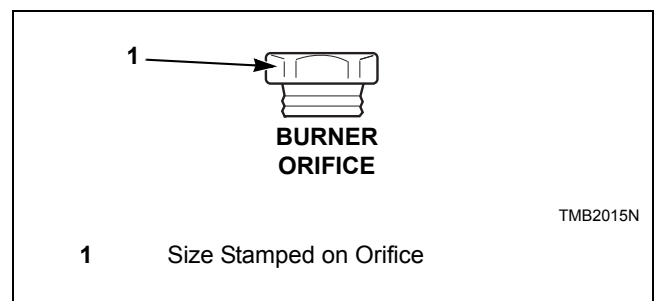



Figure 9

# Exhaust Requirements

	<b>WARNING</b>
<p><b>A drying tumble dryer produces combustible lint. To reduce the risk of fire, the tumble dryer must be exhausted to the outdoors.</b></p> <p style="text-align: right;">W057R1</p> <p><b>To reduce the risk of fire, DO NOT use plastic or thin foil ducting to exhaust the tumbler.</b></p> <p style="text-align: right;">W773</p> <p><b>To reduce the risk of fire and accumulation of combustible gases, DO NOT exhaust tumble dryer air into a window well, gas vent, chimney or enclosed, unventilated area such as an attic wall, ceiling, crawl space under a building, or concealed space of a building.</b></p> <p style="text-align: right;">W059R1</p>	

Make-up air openings in rooms containing tumble dryer(s) and/or gas fired hot water heater or other gravity vented appliances must be increased sufficiently to prevent downdrafts in any of the vents when all tumble dryers are in operation. Do not locate gravity vented appliances between tumble dryer(s) and make-up air openings. If it is necessary to duct make-up air to tumble dryer(s), increase area of duct work by 25% to compensate for restrictions in air movement.

## Venting

	<b>WARNING</b>
<p><b>To reduce the risk of fire due to increased static pressure, we do not recommend installation of in-line secondary lint filters or lint collectors. If secondary systems are mandated, frequently clean the system to assure safe operation.</b></p> <p style="text-align: right;">W749</p>	

## Layout

Whenever possible, install tumble dryers along an outside wall where duct length can be kept to a minimum, and make-up air can be easily accessed. Construction must not block the airflow at the rear of the tumble dryer. Doing so would prevent adequate air supply to the tumble dryer combustion chamber.

## Make-Up Air

A tumble dryer is forced air exhausted and requires provisions for make-up air to replace air exhausted by tumble dryer.

**IMPORTANT: Do not obstruct flow of combustion and ventilation air.**

<b>Required Make-Up Air Opening (to the outside) for Each Tumble Dryer</b>	
<b>Model</b>	<b>Opening</b>
<b>120 Series</b>	23,230 mm <sup>2</sup> (360 in <sup>2</sup> )
<b>170 Series</b>	33,870 mm <sup>2</sup> (525 in <sup>2</sup> )
<b>200 Series</b>	33,870 mm <sup>2</sup> (525 in <sup>2</sup> )

Make-up air openings with louvers will restrict airflow. The opening must be increased to compensate for area taken up by louvers.

**IMPORTANT: Installing in-line filters or lint collectors will cause increased static pressure.**

**Failure to maintain the secondary lint system will decrease tumble dryer efficiency and may void machine warranty.**

For maximum efficiency and minimum lint accumulation, tumble dryer air must be exhausted to the outdoors by the shortest possible route.

Proper sized exhaust ducts are essential for proper operation. All elbows should be sweep type. Exhaust ducts must be assembled so the interior surfaces are smooth, so the joints do not permit the accumulation of lint. DO NOT use plastic, thin foil or Type B flexible ducts - rigid metal ducts are recommended. Use exhaust ducts made of sheet metal or other noncombustible material. DO NOT use sheet metal screws or fasteners on exhaust pipe joints which extend into the duct and catch lint. Use of duct tape or pop-rivets on all seams and joints is recommended, if allowed by local codes.

Verify that old ducts are thoroughly cleaned out before installing new tumble dryer(s).

## Exhaust Requirements

	<b>WARNING</b>
<p><b>Improperly sized or assembled ductwork causes excess back pressure which results in slow drying, lint collecting in the duct, lint blowing back into the room, and increased fire hazard.</b></p>	
<small>W355</small>	

**NOTE:** Exhaust ducts must be constructed of sheet metal or other noncombustible material. Such ducts must be equivalent in strength and corrosion resistance to ducts made of galvanized sheet steel not less than 0.495 mm (0.0195 inches) thick.

Where the exhaust duct pierces a combustible wall or ceiling, the opening must be sized per local codes. The space around the duct may be sealed with noncombustible material. Refer to *Figure 12*.

**IMPORTANT:** For best performance provide an individual exhaust duct for each tumble dryer. Do not install a hot water heater in a room containing tumble dryers. It is better to have the water heater in a separate room with a separate air inlet.

### Alternate Venting for 120 Series Tumble Dryers

The 120 series tumble dryer is equipped from the factory to exhaust from the top; however, it may be converted to exhaust out the rear by doing the following (refer to *Specifications and Dimensions* section):

1. Remove belt guard cover.
2. Remove 254 mm (10 inch) diameter elbow and vertical duct.
3. Cut out shape from belt guard cover. Refer to *Figure 10*.
4. Screw octagonal piece over 254 mm (10 inch) diameter opening in top of belt guard.
5. Attach new exhaust duct to exhaust thimble on rear panel, following all requirements in this section.
6. Replace belt guard cover.

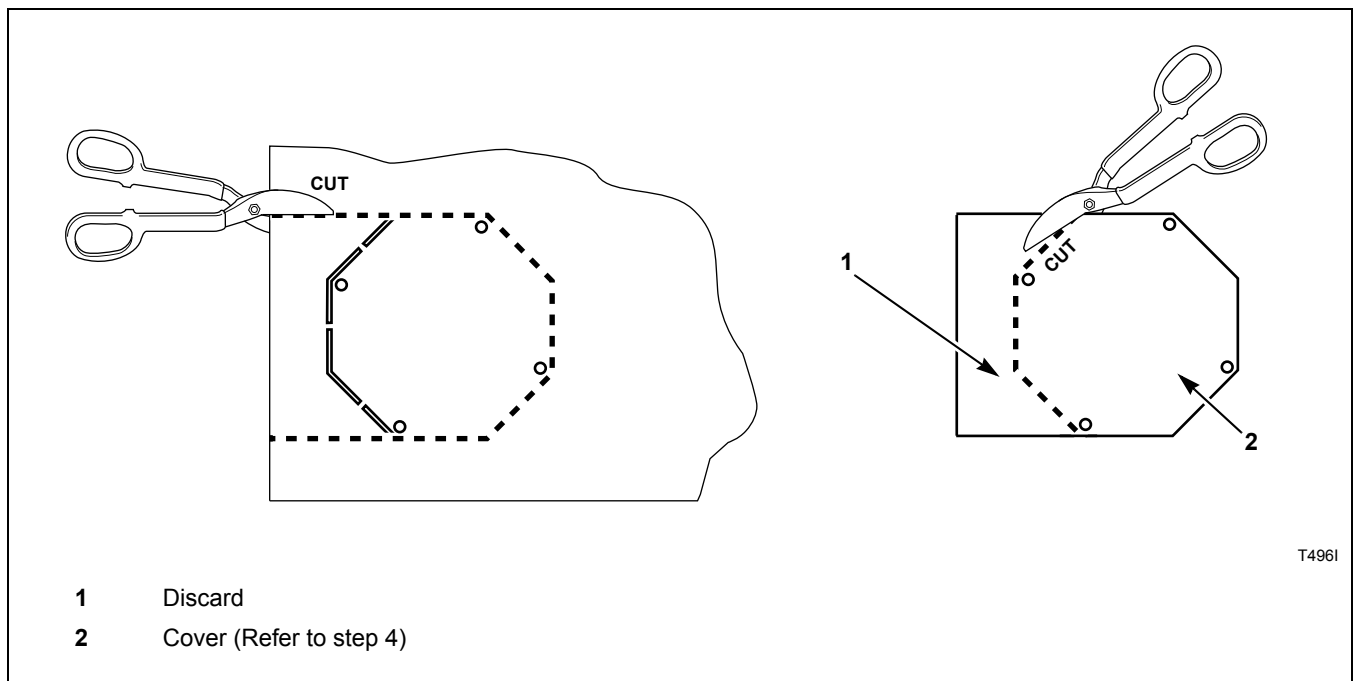

Figure 10

### Individual Venting

For maximum efficiency and performance, it is preferred to exhaust tumble dryer(s) individually to the outdoors.

**IMPORTANT:** At no point may the cross sectional area of installed venting be less than the cross sectional area of the exhaust outlet of the tumble dryer.

The exhaust duct must be designed so the static back pressure measured 305 mm (12 inches) from the exhaust outlet does not exceed the maximum allowable pressure specified on the installation sticker on the rear of the tumble dryer.

**NOTE:** Static back pressure must be measured with the tumble dryer running.

The maximum allowable length venting is 4.3 m (14 feet) and two 90° elbows or equivalent. If the equivalent length of a duct required for an installation exceeds the maximum allowable equivalent length, the diameter of a round duct must be increased by 10% for each additional 6.1 m (20 feet). Cross section area of a rectangular duct must be increased by 20% for each additional 6.1 m (20 feet). Refer to *Table 4* to determine equivalent venting.

Duct Diameter	Equivalent Length of Rigid Straight Duct
254 mm (10 in.)	One 90° elbow = 3.5 m (11.6 ft.)
305 mm (12 in.)	One 90° elbow = 4.3 m (14 ft.)
356 mm (14 in.)	One 90° elbow = 4.9 m (16 ft.)
406 mm (16 in.)	One 90° elbow = 5.7 m (18.7 ft.)
457 mm (18 in.)	One 90° elbow = 6.4 m (21 ft.)

Equivalent Length (meter) = 1.17 x Duct Diameter (mm)

Table 4

**Example:** A 305 mm (12 inch) diameter duct’s equivalent length of 4.3 m (14 feet) of duct and two 90° elbows is:

Equivalent Length  
 = 4.3 m (14 ft.) + (2) 90° elbows  
 = 4.3 m (14 ft.) + 4.3 m (14 ft.) + 4.3 m (14 ft.)=  
 12.8 m (42 ft.)

With the tumble dryer in operation, airflow at any point in the duct should be at least 366 m/min. (1200 feet/min.) to ensure that lint remains airborne. If 366 m/min. (1200 feet/min.) per minute cannot be

maintained, schedule monthly inspections and cleaning of the ductwork.

**NOTE:** The maximum length of a flexible metal duct must not exceed 2.4 m (7.87 ft.) as required to meet UL2158, clause 7.3.2A.

### Manifold Venting

While it is preferable to exhaust tumble dryers individually to the outdoors, a main collector duct may be used if it is sized according to *Figure 13*. This illustration indicates minimum diameters, and should be increased if collector length exceeds 6.1 meters (20 feet). Manifold duct may be rectangular in cross section, as long as area is not reduced. Provisions should be made for lint removal and cleaning of duct.

Manifold duct must be tapered, as shown in *Figure 11*. Individual tumble dryer ducts must enter manifold duct at a 45° angle in the direction of airflow.

The vent collector system must be designed so the static back pressure measured 305 mm (12 inches) from the exhaust outlet does not exceed the maximum allowable pressure of 1.3 bar (0.5 W.C.I.) as specified on the installation sticker on the rear of tumble dryer. Static back pressure must be measured with all tumble dryers vented into the collector operating.

**NOTE:** Never connect a tumble dryer duct at a 90° angle to the collector duct. Refer to *Figure 11*. Doing so will cause excessive back pressure, resulting in poor performance. Never connect two tumble dryer exhaust ducts directly across from each other at the point of entry to the collector duct.

With the tumble dryer in operation, airflow at any point in the duct should be at least 366 m/min. (1200 feet/min.) to ensure that lint remains airborne. If 366 m/min. (1200 feet/min.) cannot be maintained, schedule monthly inspections and cleaning of the ductwork.

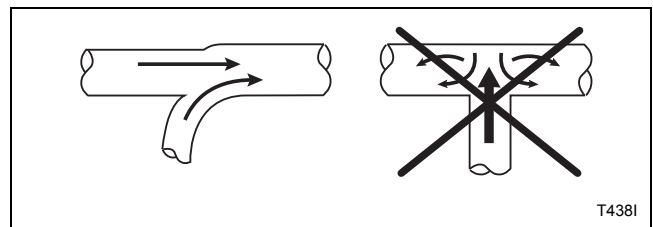

Figure 11

## Exhaust Requirements

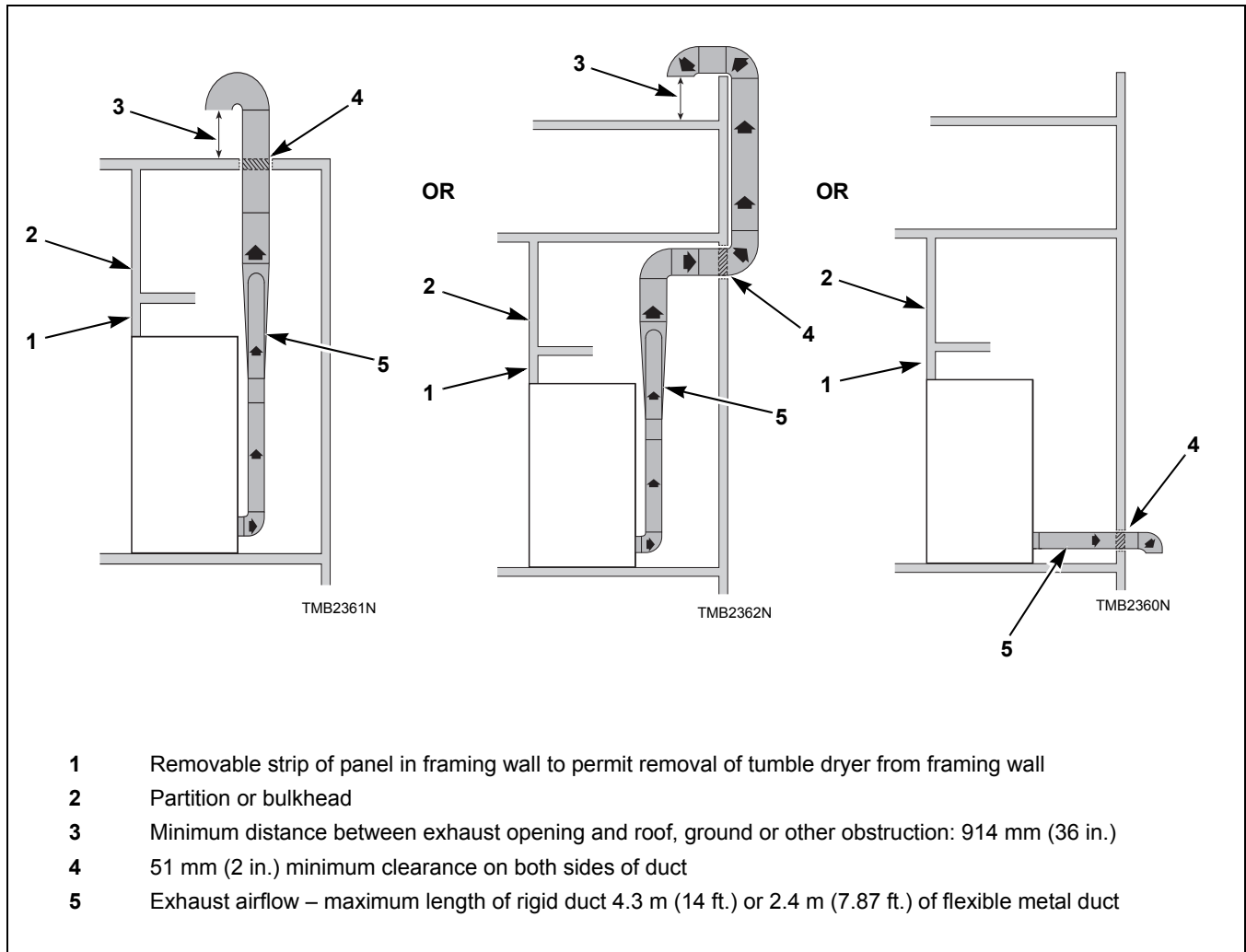

Figure 12

**NOTE: Do not install wire mesh or screen in exhaust duct opening to avoid lint build-up or impacting proper discharge of air from tumble dryers.**

**NOTE: Where exhaust duct pierces a combustible wall or ceiling, the opening must be sized per local codes.**

**NOTE: Inside of duct must be smooth. Do not use sheet metal screws to join sections.**

Consult your local building code for regulations which may also apply.







# Gas Requirements

	<b>WARNING</b>
<p><b>To reduce the risk of fire or explosion, DO NOT CONNECT THE GAS LINE TO THE TUMBLE DRYER IF THE GAS SERVICE IS NOT THE SAME AS THAT SPECIFIED ON THE TUMBLE DRYER SERIAL PLATE! It will first be necessary to convert the gas burner orifice and gas valve. Appropriate conversion kits are available.</b></p> <p style="text-align: right;">W060R1</p>	
<p><b>To reduce the risk of gas leaks, fire or explosion, use a new flexible stainless steel connector.</b></p> <p style="text-align: right;">W774</p>	

**IMPORTANT:** Any product revisions or conversions must be made by the Manufacturer's Authorized Dealers, Distributors or local service personnel.

**IMPORTANT:** The tumble dryer must be isolated from the gas supply piping system by closing its individual manual shut-off valve during any pressure testing of the gas supply piping system at test pressure equal to or less than 3.45 kPa, 34.5 mbar (0.5 psig).

**NOTE:** For gas valves with a manual shut-off switch on the gas valve, the shut-off switch does not protect the valve from this pressure test. Use the individual manual shut-off valve from the gas supply piping system to protect the gas valve.

**IMPORTANT:** The tumble dryer and its manually operated appliance gas valve must be disconnected from the gas supply piping system during any pressure testing of that system at test pressures in excess of 3.45 kPa, 34.5 mbar (0.5 psig).

**IMPORTANT:** The installation must comply with local codes or, in the absence of local codes:

- with the latest edition of the "National Fuel Gas Code," ANSI Z223.1/NFPA 54 in the U.S.A.
- with CAN/CSA-B149.1 Natural Gas and Propane Installation Code in Canada
- and Gas Installations Standard AS/NZS 5601 Part 1: General Installations in Australia and New Zealand

Obtain specific gas service pipe size from the gas supplier. Refer to *Table 7* for general pipe size.

The following must be furnished and installed by the customer for the gas service line to each tumble dryer. Refer to *Figure 15*.

- Sediment traps
- Shut-off valves
- Supply pressure taps

It is important that equal pressure be maintained at all tumble dryer gas connections. This can be done by installing a 25.4 mm (1 inch) pipe gas loop to maintain equal pressure at all gas connections. Refer to *Figure 16*.

	<b>WARNING</b>
<p><b>To reduce the risk of fire or explosion, if the tumble dryer is to be connected to Liquefied Petroleum (L.P.) gas, a vent to the outdoors must be provided in the room where the tumble dryer is installed.</b></p> <p style="text-align: right;">W062R1</p>	

NATURAL GAS pressures with all gas appliances running (tumble dryers, water heaters, space heaters, furnace, etc.):

Maximum gas pressure – 26.1 mbar (10.5 water column inches)

Recommended gas pressure – 16.2 mbar (6.5 water column inches)

Minimum gas pressure – 12.4 mbar (5 water column inches)

An in-line pressure regulator may be required if the line pressure exceeds 26.1 mbar (10.5 water column inches) with all gas appliances running.

LIQUID PETROLEUM GAS (L.P.) pressures with all gas appliances running (tumble dryers, water heaters, space heaters, furnace, etc.):

Maximum gas pressure – 32.3 mbar (13 water column inches)

Recommended gas pressure – 27.4 mbar (11 water column inches)

Minimum gas pressure – 24.9 mbar (10 water column inches)

For converting models from Natural Gas to L.P. Gas:

120 Series Models - M4973P3

170 Series Models - M4974P3

200 Series Models - M4975P3

## Gas Requirements

Turn on gas and check all pipe connections (internal and external) for gas leaks with a non-corrosive leak detection fluid. Purge air in gas service line by operating the tumble dryers in the drying mode. If burner does not light and unit goes into lockout, open and close the door and restart. Repeat these steps until burner ignites. **Use pipe compound, resistant to actions of L.P. gas, on all pipe threads.**

	<h3>WARNING</h3>
<p><b>Check all pipe connections, internal and external, for gas leaks using a non-corrosive leak detection fluid. To reduce the risk of explosion or fire, DO NOT USE AN OPEN FLAME TO CHECK FOR GAS LEAKS! Gas connections should be checked twice a year for leakage.</b></p>	
<small>W635</small>	

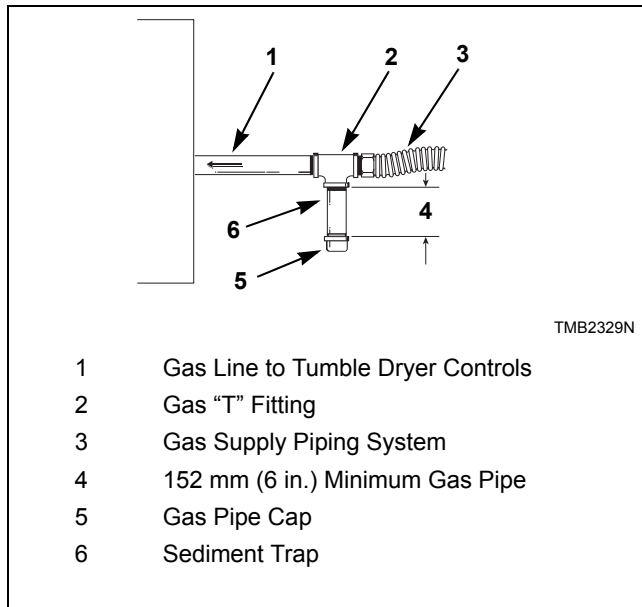
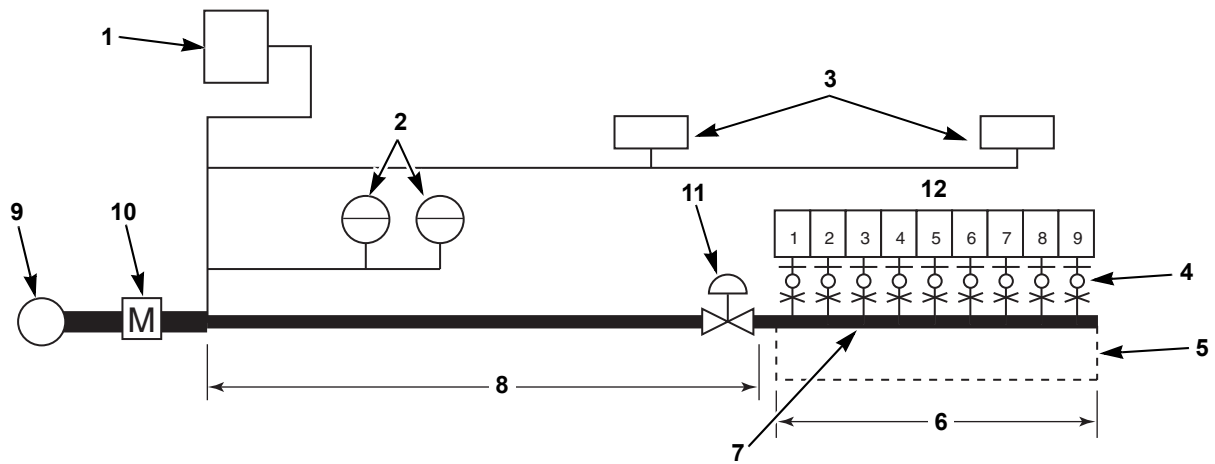

Figure 15

## Gas Supply Pipe Sizing and Looping



TMB2126N

<b>1</b>	Gas furnace (35.2 kW [120,000 Btu/hr.])	<b>8</b>	7.6 m (25 ft.)
<b>2</b>	Gas water heaters (117.2 kW [400,000 Btu/hr. each])	<b>9</b>	Main regulator
<b>3</b>	Gas space heaters (20.5 kW [70,000 Btu/hr. each])	<b>10</b>	Gas meter
<b>4</b>	Sediment traps, supply pressure taps and shut-off valves. Refer to <i>Figure 15</i> .	<b>11</b>	Pressure regulator (if required)
<b>5</b>	25.4 mm (1 in.) gas pipe loop	<b>12</b>	120 Series Tumble Dryers (79.13 kW [270,000 Btu/hr. each])
<b>6</b>	5.8 m (19 ft.)		170 Series Tumble Dryers (115.77 kW [395,000 Btu/hr. each])
<b>7</b>	Minimum Pipe Size to Tumble Dryer is 19 mm (0.75 in.) for 120 Series Gas, 25 mm (1 in.) for 170 and 200 Series Gas.		200 Series Tumble Dryers (124.56 kW [425,000 Btu/hr. each])

### SAMPLE CALCULATIONS:

Equivalent length = Total length of main gas supply pipe to the far end of the Tumble Dryers.  
 = 7.6 m + 5.8 m (25 ft. + 19 ft.) gas supply pipe  
 = 13.4 m (44 ft.) Total Gas Line

Total Btu/hr. = The sum of the Btu/hr. of all 120 series tumble dryers being fed by the main gas supply pipe.  
 = 9 x 79.13 (270,000)  
 = 712.17 kW (2,430,000 Btu/hr.)

Using *Table 7*, the main supply pipe diameter should be 76 mm (3 in.).

**IMPORTANT: Gas loop piping must be installed as illustrated to equalize gas pressure for all tumble dryers connected to single gas service. Other gas using appliances should be connected upstream from loop.**

Figure 16

**Gas Requirements**

<b>Gas Pipe Size Required for 1000 Btu Natural Gas — 17.4 ± 4 mbar, 1.74 ± 0.37 kPa (0.64 Specific Gravity at 7 ± 1.5 inches) Water Column Pressure</b>						
<b>Gas Appliances Total Btu/hr.</b>	<b>Equivalent Length</b>					
	<b>7.63 m (25 feet)</b>	<b>15.25 m (50 feet)</b>	<b>22.88 m (75 feet)</b>	<b>30.50 m (100 feet)</b>	<b>38.13 m (125 feet)</b>	<b>45.75 m (150 feet)</b>
<b>Based on 0.3 in. Water Column Pressure Drop for Length Given Sizes shown in mm (inches)</b>						
<b>100,000</b>	19.05 (0.75)	19.05 (0.75)	25.40 (1)	25.40 (1)	25.40 (1)	25.40 (1)
<b>120,000</b>	19.05 (0.75)	25.40 (1)	25.40 (1)	25.40 (1)	25.40 (1)	25.40 (1)
<b>140,000</b>	19.05 (0.75)	25.40 (1)	25.40 (1)	25.40 (1)	25.40 (1)	31.75 (1.25)
<b>160,000</b>	19.05 (0.75)	25.40 (1)	25.40 (1)	31.75 (1.25)	31.75 (1.25)	31.75 (1.25)
<b>180,000</b>	25.40 (1)	25.40 (1)	25.40 (1)	31.75 (1.25)	31.75 (1.25)	31.75 (1.25)
<b>200,000</b>	25.40 (1)	25.40 (1)	31.75 (1.25)	31.75 (1.25)	31.75 (1.25)	38.10 (1.5)
<b>300,000</b>	25.40 (1)	31.75 (1.25)	31.75 (1.25)	38.10 (1.5)	38.10 (1.5)	38.10 (1.5)
<b>400,000</b>	31.75 (1.25)	31.75 (1.25)	38.10 (1.5)	38.10 (1.5)	38.10 (1.5)	50.80 (2)
<b>500,000</b>	31.75 (1.25)	38.10 (1.5)	38.10 (1.5)	50.80 (2)	50.80 (2)	50.80 (2)
<b>600,000</b>	38.10 (1.5)	38.10 (1.5)	50.80 (2)	50.80 (2)	50.80 (2)	50.80 (2)
<b>700,000</b>	38.10 (1.5)	50.80 (2)	50.80 (2)	50.80 (2)	50.80 (2)	63.50 (2.5)
<b>800,000</b>	38.10 (1.5)	50.80 (2)	50.80 (2)	50.80 (2)	63.50 (2.5)	63.50 (2.5)
<b>900,000</b>	50.80 (2)	50.80 (2)	50.80 (2)	63.50 (2.5)	63.50 (2.5)	63.50 (2.5)
<b>1,000,000</b>	50.80 (2)	50.80 (2)	50.80 (2)	63.50 (2.5)	63.50 (2.5)	63.50 (2.5)
<b>1,100,000</b>	50.80 (2)	50.80 (2)	63.50 (2.5)	63.50 (2.5)	63.50 (2.5)	63.50 (2.5)
<b>1,200,000</b>	50.80 (2)	50.80 (2)	63.50 (2.5)	63.50 (2.5)	63.50 (2.5)	63.50 (2.5)
<b>1,300,000</b>	50.80 (2)	63.50 (2.5)	63.50 (2.5)	63.50 (2.5)	63.50 (2.5)	76.20 (3)
<b>1,400,000</b>	50.80 (2)	63.50 (2.5)	63.50 (2.5)	63.50 (2.5)	76.20 (3)	76.20 (3)
<b>1,500,000</b>	50.80 (2)	63.50 (2.5)	63.50 (2.5)	63.50 (2.5)	76.20 (3)	76.20 (3)
<b>1,600,000</b>	50.80 (2)	63.50 (2.5)	63.50 (2.5)	76.20 (3)	76.20 (3)	76.20 (3)
<b>1,700,000</b>	50.80 (2)	63.50 (2.5)	63.50 (2.5)	76.20 (3)	76.20 (3)	76.20 (3)
<b>1,800,000</b>	63.50 (2.5)	63.50 (2.5)	76.20 (3)	76.20 (3)	76.20 (3)	76.20 (3)
<b>1,900,000</b>	63.50 (2.5)	63.50 (2.5)	76.20 (3)	76.20 (3)	76.20 (3)	76.20 (3)
<b>2,000,000</b>	63.50 (2.5)	63.50 (2.5)	76.20 (3)	76.20 (3)	76.20 (3)	88.90 (3.5)
<b>2,200,000</b>	63.50 (2.5)	76.20 (3)	76.20 (3)	76.20 (3)	88.90 (3.5)	88.90 (3.5)
<b>2,400,000</b>	63.50 (2.5)	76.20 (3)	76.20 (3)	76.20 (3)	88.90 (3.5)	88.90 (3.5)
<b>2,600,000</b>	63.50 (2.5)	76.20 (3)	76.20 (3)	88.90 (3.5)	88.90 (3.5)	88.90 (3.5)
<b>2,800,000</b>	63.50 (2.5)	76.20 (3)	76.20 (3)	88.90 (3.5)	88.90 (3.5)	88.90 (3.5)
<b>3,000,000</b>	63.50 (2.5)	76.20 (3)	88.90 (3.5)	88.90 (3.5)	88.90 (3.5)	101.60 (4)

**For L.P. Gas, correct the total Btu/hr by multiplying it by 0.6. The answer is the equivalent Btu on the above chart.**

Table 7

## High Altitude Orifice Sizing

For proper operation at altitudes above 610 meters (2000 feet), the gas orifice size must be reduced to ensure complete combustion. Refer to *Table 8*.

For CE models, consult local gas supplier.

Model	Gas	Altitude		Orifice				New Rate (Btu/hr.)*	
		m	feet	No.	mm	inches	Quantity		Part No.
120L/N	Natural Gas	610 – 1220	2001 – 4000	16	4.5	0.1770	3	M402988	248,400
		1221 – 1830	4001 – 6000	18	4.3	0.1695		M402995	226,800
		1831 – 2440	6001 – 8000	19	4.2	0.1660		M401002	205,200
		2441 – 3050	8001 – 10,000	20	4.1	0.1610		M401020	183,600
	L.P. Gas	610 – 1220	2001 – 4000	38	2.6	0.1015		M411376	248,400
		1221 – 1830	4001 – 6000	39	2.5	0.0995		M401007	226,800
		1831 – 2440	6001 – 8000	41	2.4	0.0960		M401015	205,200
		2441 – 3050	8001 – 10,000	42	2.4	0.0935		M403017	183,600
170L/N	Natural Gas	610 – 1220	2001 – 4000	14	4.6	0.1820	4	M411371	363,400
		1221 – 1830	4001 – 6000	16	4.5	0.1770		M411373	331,800
		1831 – 2440	6001 – 8000	17	4.4	0.1730		M411374	300,200
		2441 – 3050	8001 – 10,000	19	4.2	0.1660		M402995	268,600
	L.P. Gas	610 – 1830	2001 – 6000	30	3.3	0.1285	3	M401021	363,400
		1831 – 3050	6001 – 10,000	31	3.0	0.1200		M401017	300,200
200L/N	Natural Gas	610 – 1220	2001 – 4000	19	4.2	0.1660	5	M402995	391,000
		1221 – 1830	4001 – 6000	20	4.1	0.1610		M401002	357,000
		1831 – 2440	6001 – 8000	22	4.0	0.1570		M402996	323,000
		2441 – 3050	8001 – 10,000	24	3.9	0.1520		M402980	289,000
	L.P. Gas	610 – 1220	2001 – 4000	33	2.9	0.1130	4	M401022	391,000
		1221 – 1830	4001 – 6000	34	2.8	0.1110		M411512	357,000
		1831 – 2440	6001 – 8000	7/64	2.8	0.1094		70070902	323,000
		2441 – 3050	8001 – 10,000	37	2.6	0.1040		M401024	289,000

\* Btu/hr. derate of 4% per 305 m (1000 ft.) of altitude.

Table 8

# Electrical Requirements

	<b>WARNING</b>
<p>To reduce the risk of electric shock, fire, explosion, serious injury or death:</p> <ul style="list-style-type: none"><li>• Disconnect electric power to the tumble dryer before servicing.</li><li>• Close gas shut-off valve to gas tumble dryer before servicing.</li><li>• Close steam valve to steam tumble dryer before servicing.</li><li>• Never start the tumble dryer with any guards/panels removed.</li><li>• Whenever ground wires are removed during servicing, these ground wires must be reconnected to ensure that the tumble dryer is properly grounded.</li></ul> <p style="text-align: right;">W002R1</p>	
<p>To reduce the risk of fire and electric shock, check with a qualified serviceman for proper grounding procedures. Improper connection of the equipment grounding conductor may result in a risk of electric shock.</p> <p style="text-align: right;">W068</p>	
<p>To reduce the risk of fire and electric shock, if electrical supply is coming from a three phase service, <b>DO NOT</b> connect a “High Leg” or “Stinger Leg” to a single phase machine. On a three phase machine, if there is a “High Leg” or “Stinger Leg” it should be connected to L3.</p> <p style="text-align: right;">W069</p>	

**IMPORTANT:** Electrical connections must be made by a qualified electrician using data on serial plate, installation manuals and wiring diagram provided with machine and according to local codes. Install a circuit breaker as close to the tumble dryer as possible. If more than one tumble dryer is being installed, a circuit breaker must be provided for each.

**NOTE:** Connect machine to an individual branch circuit not shared with lighting or other equipment.

**NOTE: 3 Phase Machines Only - Do not use fuses to avoid the possibility of “single phasing” and causing premature failure of the motors.**

	<b>WARNING</b>
<p>In case of servicing (or putting the tumble dryer out of order), disconnect the tumble dryer from the main supply by switching off the circuit breaker.</p> <p style="text-align: right;">W796</p>	

## Wiring Diagram

The wiring diagram is located in the junction or contactor box.

The wiring diagram part number is in the lower portion of the electrical data on the serial plate.



## Grounding Instructions

**NOTE:** To ensure protection against shock, this tumble dryer **MUST** be electrically grounded in accordance with the local codes, or in the absence of local codes, with the latest edition of the National Electrical Code ANSI/NFPA No. 70. In Canada the electrical connections are to be made in accordance with CSA C22.1 latest edition Canadian Electrical Code, or local codes. Electrical work should be done by a qualified electrician.

This tumble dryer must be grounded. In the event of malfunction or breakdown, grounding will reduce the risk of electric shock by providing a path of least resistance for electric current. This tumble dryer must be connected to a grounded metal, permanent wiring system; or an equipment grounding conductor must be run with the circuit conductors and connected to the appropriate ground location.

- Metal conduit and/or BX cable is not considered ground.
- Connecting the Neutral from the electrical service box to the tumble dryer ground screw does not constitute a ground.
- A dedicated ground conduit (wire) must be connected between the electrical service box ground bar and tumble dryer ground screw.

## For CE Models Only

All models are factory-equipped with an emergency stop button on the front panel.

**NOTE:** Activation of the emergency stop switch stops all machine control circuit functions, but **DOES NOT** remove all electrical power from machine.

	<b>WARNING</b>
<p><b>To reduce the risk of electrical shock, de-energize the electrical circuit being connected to the tumble dryer before making any electrical connections. All electrical connections should be made by a qualified electrician. Never attempt to connect a live circuit.</b></p>	
<small>W409R1</small>	

	<b>CAUTION</b>
<p><b>Label all wires prior to disconnection when servicing controls. Wiring errors can cause improper and dangerous operation. Verify proper operation after servicing.</b></p>	
<small>W071</small>	

Electrical Requirements

Service/Ground Location

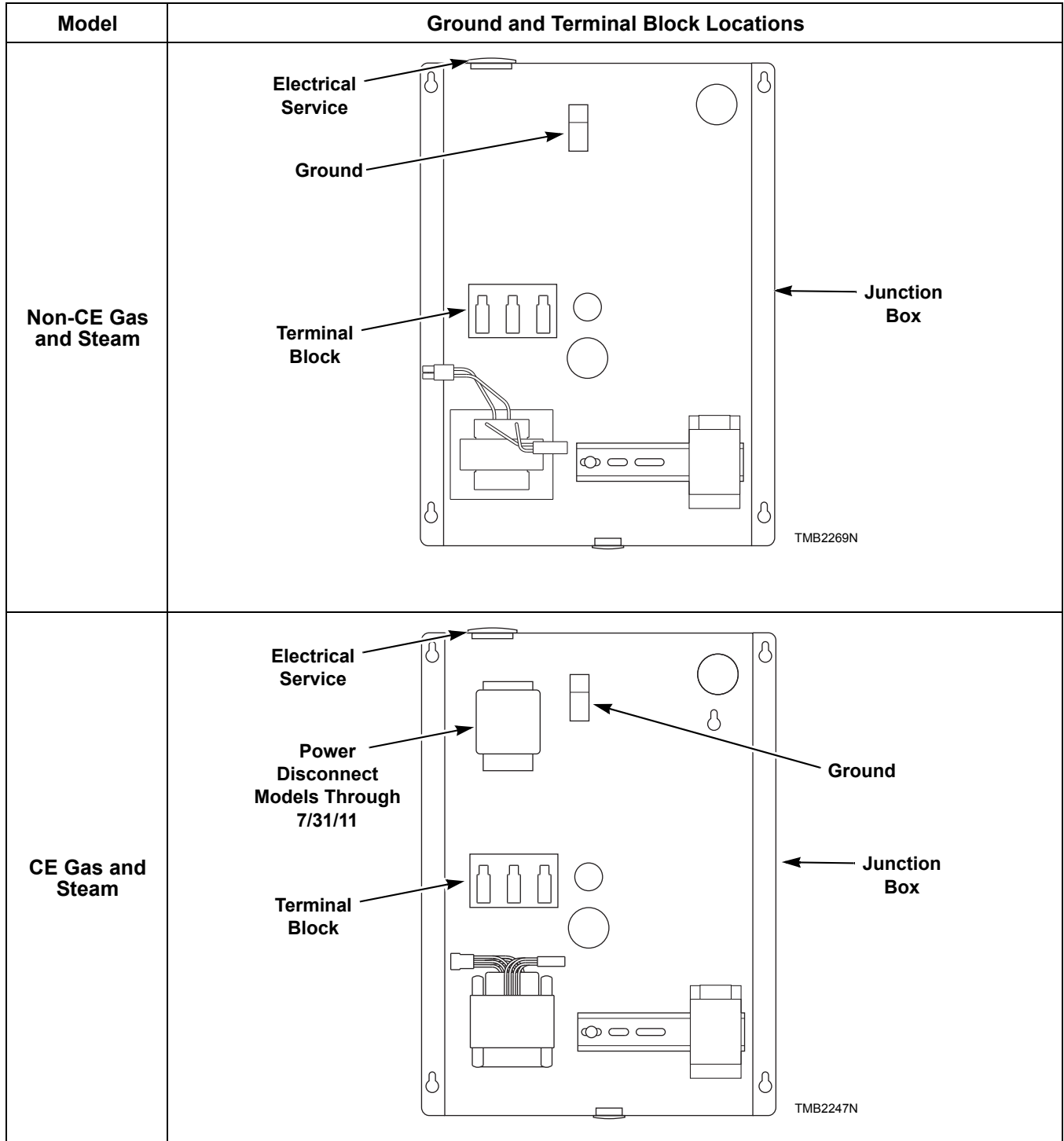

Figure 17 (continued)

Figure 17 (continued)

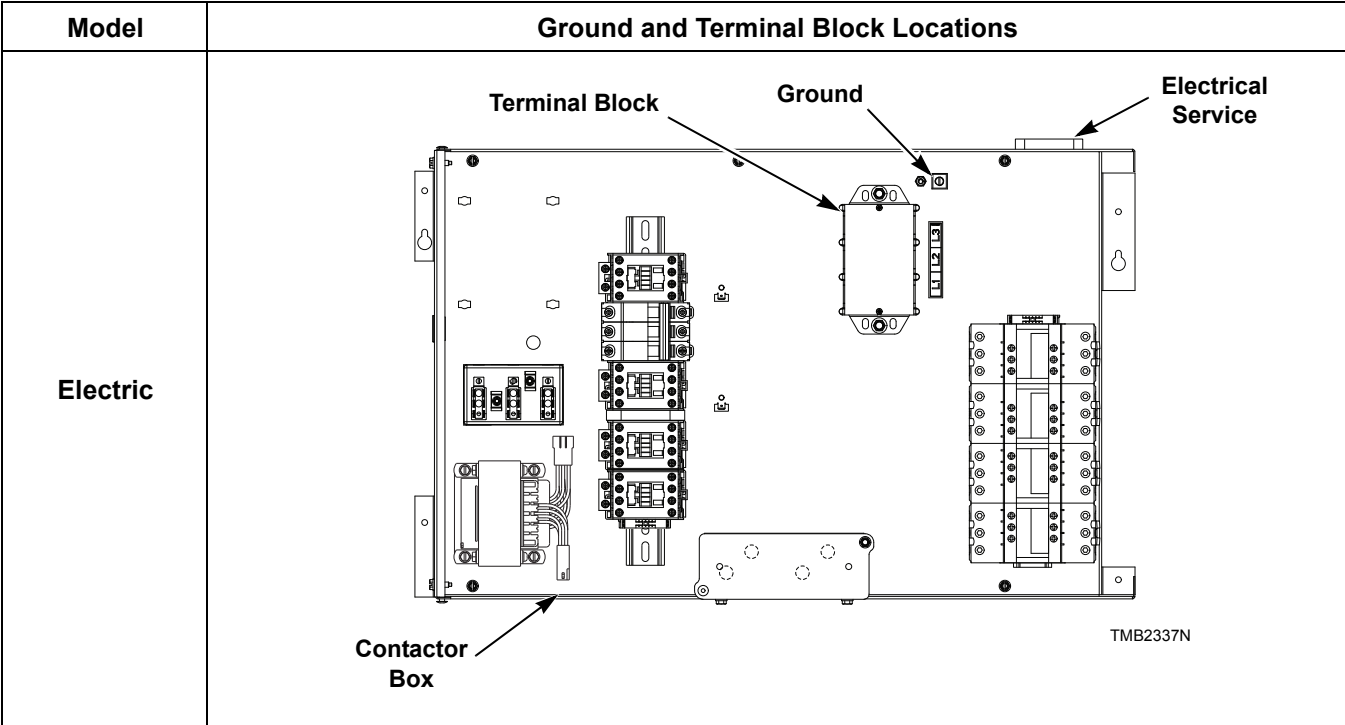

Figure 17

## Electrical Requirements

### To Connect Electrical Service To The Tumble Dryer

The following steps outline the procedure for connecting the electrical service to the tumble dryer.

**NOTE: The wiring diagram is located in the junction box.**

1. Install a circuit breaker as close to the tumble dryer as possible. If more than one tumble dryer is being installed, a disconnect switch or circuit breaker should be provided for each. This will make it possible to disconnect each tumble dryer for maintenance purposes.
2. Connect the conduit-encased leads to the disconnect switch, or circuit breaker. Connect the wire leads to the appropriate labeled terminal on the terminal block. The ground wire must be connected to the ground connection as shown in *Figure 17*.
3. Check the electrical service phase sequence (three phase only). If one of the power leads is a “high leg,” connect it to lead L3 in the tumble dryer. The cylinder must rotate clockwise and the fan must rotate counterclockwise (as viewed from the front of the tumble dryer – with selector switch in non-reverse position). If not, interchange leads L1 and L2 in the tumble dryer connection box.

## Jumper Configuration Instructions

Changing the transformer configuration jumper is required, **PRIOR TO SUPPLYING POWER TO THE MACHINE**, if any of the following apply:

**IMPORTANT: Failure to install the proper configuration jumper may result in damage to sensitive electronic controls and may void warranty.**

- You have 400 – 415 Volt service and are connecting a model rated for 380 Volt operation.

## Ferrite Ring Installation

**Gas and Steam Models with RM Control Suffix Only (Models Through 7/31/11)**

The ferrite ring provided in the literature packet must be installed over the power leads during connection of

electrical service. The ferrite protects the sensitive electronic controls from destructive electrical disturbances which may be present on power lines to the machine. Failure to properly install the ferrite ring may result in damage to the electronic controls and will void control warranty.

To install:

- Immediately after connection of power leads and before applying power to machine, locate each of the incoming service leads including ground.
- Snap the ferrite ring closed over all the service leads inside of the contactor box as shown. It is important that the ferrite ring be installed inside the contactor box. Refer to *Figure 18*. Do not install the ferrite outside of the box or other area. Make sure that service leads are in the center of the ferrite before closing the ring so as not to pinch or damage leads.

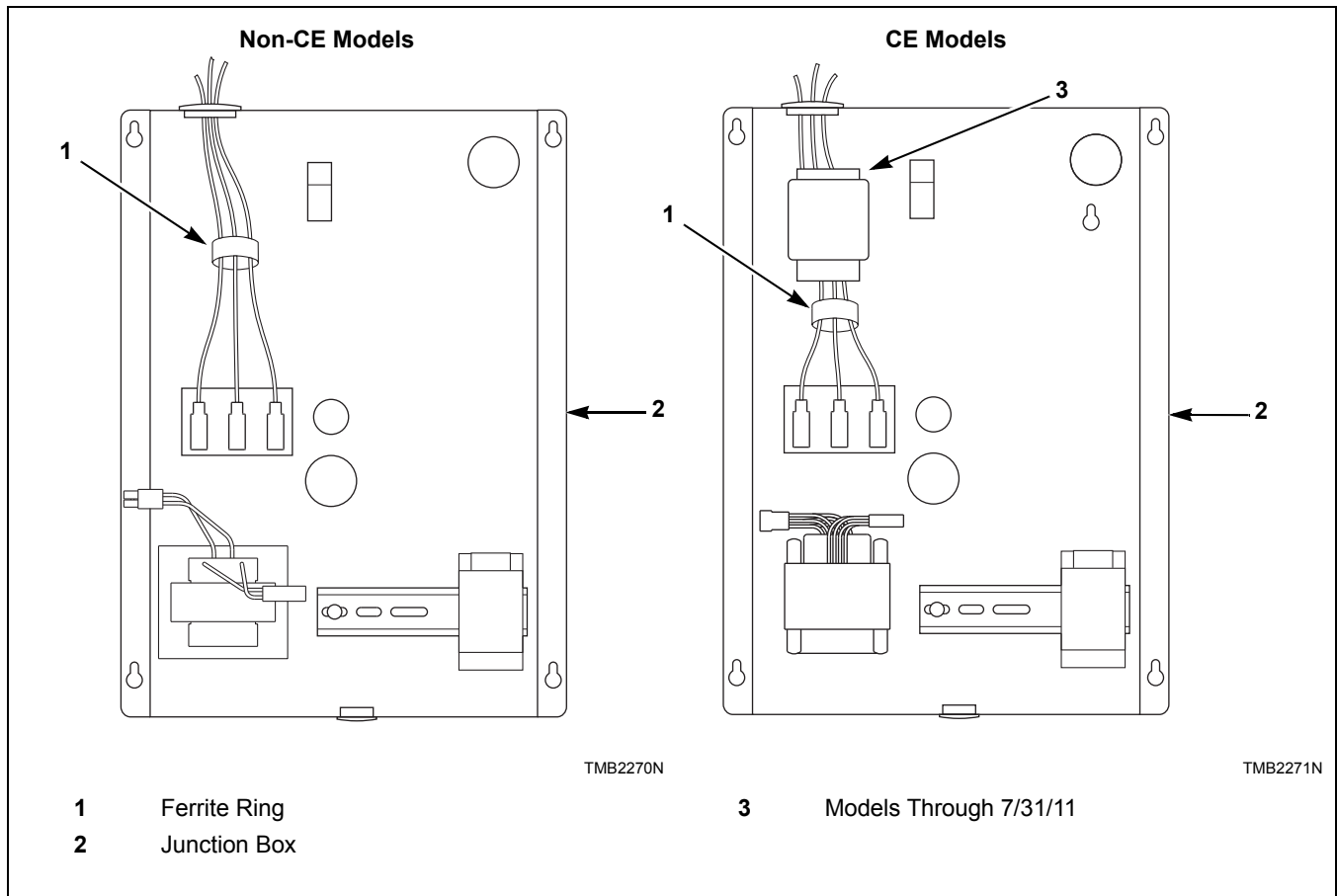

Figure 18

## Electrical Requirements

### Electrical Specifications

NOTE: Minimum wire sizes are obtained from Canadian Electrical Code and are intended for use as a guideline only. Electrical connections should be made only by a qualified electrical contractor in accordance with all applicable local and national requirements.

NOTE: Electrical specifications below are subject to change without notice. Always refer to product serial plate for most current specifications of product being installed.

NOTE: Use copper conductors only.

NOTE: Connect to individual branch circuit.

NOTE: 3 Phase Only – Each tumble dryer must be connected to its own individual branch circuit breaker, not fuses, to avoid the possibility of “single phasing” and causing premature failure of the motor(s).

#### For 120 Series Gas and Steam Tumble Dryer Models

Serial Plate Rating	Terminal Block Connections Required	Rated Current* (amps)	Breaker Rating	Recommended Wire Size mm <sup>2</sup> (AWG)
200-208/240V/60Hz/3ph	L1,L2,L3 and ground	7.7	15A - 3 pole	2.5 (14)
230V/50Hz/3ph	L1,L2,L3 and ground	7.3	15A - 3 pole	2.5 (14)
380V/50 or 60Hz/3ph	L1,L2,L3 and ground	4.1	10A - 3 pole	2.5 (14)
400-415V/50Hz/3ph	L1,L2,L3 and ground	3.8	10A - 3 pole	2.5 (14)
440V/60Hz/3ph	L1,L2,L3 and ground	3.8	10A - 3 pole	2.5 (14)
460-480V/60Hz/3ph	L1,L2,L3 and ground	3.9	10A - 3 pole	2.5 (14)

\* Current ratings vary slightly depending on model; refer to serial plate.

Table 9

#### For 120 Series Electric Tumble Dryer Models

Serial Plate Rating	Terminal Block Connections Required	Rated Current* (amps)	Breaker Rating	Recommended Wire Size mm <sup>2</sup> (AWG)
240V/60Hz/3ph	L1,L2,L3 and ground	152	175A - 3 pole	95 (3/0)
380V/50 or 60Hz/3ph	L1,L2,L3 and ground	94.5	125A - 3 pole	35 (1)
400-415V/50Hz/3ph	L1,L2,L3 and ground	87	125A - 3 pole	35 (1)
480V/60Hz/3ph	L1,L2,L3 and ground	76.1	100A - 3 pole	26.2 (3)

\* Current ratings vary slightly depending on model; refer to serial plate.

Table 10

#### For 170 Series Tumble Dryer Models

Serial Plate Rating	Terminal Block Connections Required	Rated Current* (amps)	Breaker Rating	Recommended Wire Size mm <sup>2</sup> (AWG)
200-208/240V/60Hz/3ph	L1,L2,L3 and ground	13.5	20A - 3 pole	4 (12)
380V/50 or 60Hz/3ph	L1,L2,L3 and ground	6.9	15A - 3 pole	2.5 (14)
400-415V/50Hz/3ph	L1,L2,L3 and ground	6.9	15A - 3 pole	2.5 (14)
440V/60Hz/3ph	L1,L2,L3 and ground	6.4	15A - 3 pole	2.5 (14)
460-480V/60Hz/3ph	L1,L2,L3 and ground	6.7	15A - 3 pole	2.5 (14)

\* Current ratings vary slightly depending on model; refer to serial plate.

Table 11

**For 200 Series Tumble Dryer Models**

<b>Serial Plate Rating</b>	<b>Terminal Block Connections Required</b>	<b>Rated Current*</b>	<b>Breaker Rating</b>	<b>Recommended Wire Size mm<sup>2</sup> (AWG)</b>
<b>200-208/240V/60Hz/3ph</b>	L1, L2, L3 and ground	14	20A - 3 pole	4 (12)
<b>380V/50 or 60Hz/3ph</b>	L1, L2, L3 and ground	8	15A - 3 pole	2.5 (14)
<b>400-415V/50Hz/3ph</b>	L1, L2, L3 and ground	8	15A - 3 pole	2.5 (14)
<b>440V/60Hz/3ph</b>	L1, L2, L3 and ground	7	15A - 3 pole	2.5 (14)
<b>460-480V/60Hz/3ph</b>	L1, L2, L3 and ground	7	15A - 3 pole	2.5 (14)

\* Current ratings vary slightly depending on model; refer to serial plate.

Table 12

# Steam Requirements

**NOTE: Machines require a constant 5.3 to 6.9 bar (80 to 100 psig) steam service for optimum operation. The maximum allowable steam pressure for use with 50 Hertz tumble dryers is 8.6 bar (125 psig). In no case may the pressure exceed the above value.**

Obtain specific steam service pipe sizes from steam system supplier or a qualified steam fitter.

- Refer to *Figure 19* and *Figure 20* for proper steam pipe configurations.
- To prevent condensate draining from headers to tumble dryer, piping should have a minimum 305 mm (12 inch) rise above respective header. Do not make steam connection to header with a horizontal or downward facing tee or elbow.
- Whenever possible, horizontal runs of steam lines must drain, by gravity, to respective steam header. Water pockets, or an improperly drained steam header will provide wet steam, causing improper operation of tumble dryer. If pockets or improper drainage cannot be eliminated, install a bypass trap to drain condensate from the low point in the steam header to the return.
- In both steam supply and steam return line, it is recommended that each have a pipe union and shut-off valve. This will enable you to disconnect the steam connections and service the tumble dryer while your laundry facility is in operation.
- Connect the steam solenoid valve to the related steam coil inlet connection with nipples, flex hoses, unions and tees.
- Strainers may require cleaning due to materials from hoses or pipes.
- Install vacuum breaker (optional), bucket trap with built-in strainer and check valve. For successful operation of tumble dryer, install trap 457 mm (18 inches) below coil and as near to the tumble dryer as possible. Inspect trap carefully for inlet and outlet markings and install according to trap manufacturer's instructions. If steam is gravity returned to boiler, omit trap but install vacuum breaker and check valve in return line near tumble dryer. Gravity return requires entire return plumbing be below steam coil outlets.
- Install union and shut-off valve in return line and make final pipe connections to return header.

**NOTE: To prevent water hammering, route return lines below outlets of steam coils.**

## Piping Recommendations

- Trap each steam coil individually. Always keep the trap clean and in good working condition.
- When tumble dryer is on the end of a line of equipment, extend header at least 1.2 m (4 feet) beyond tumble dryer. Install shut-off valve, union, check valve and bypass trap at end of line. If gravity return to boiler, omit trap.
- Insulate steam supply and return lines for safety of operator and safety while servicing tumble dryer.

	<b>WARNING</b>
<p><b>All system components must have a 8.6 bar (125 psig) working pressure. Shut-off valves must be installed upstream of the steam solenoid valve and downstream of each steam trap so components can be isolated for maintenance or emergency purposes.</b></p> <p><b>All components (solenoid valve, traps) must be supported to minimize loads on the tumbler steam coil connections.</b></p>	
<small>W701</small>	



## Installing Steam Trap and Making Condensate Return Connections

The steam trap must be installed and the coil outlet connections must be connected to the condensate return lines. The following steps outline the procedure for installing the steam trap and connecting the condensate return lines. Refer to *Figure 19* and *Figure 20* for typical installations.

1. Use flexible lines between steam inlet solenoid and steam coils, as well as outlet between steam coil and traps.
2. If necessary, install a strainer at the end of each flexible hose.
3. Install a steam trap to each strainer.

**IMPORTANT: Steam trap must be installed a minimum of 457 mm (18 inches) below the steam coil outlet connections.**

4. Install a shut-off valve to each steam trap.
5. Connect to the condensate return lines.
6. For steam solenoid valve wiring connections, refer to Wiring Diagram supplied with tumble dryer.

## Thermal Oil Prep

It is the responsibility of the customer to install appropriate coil and heating system for thermal oil prep models. The producer is not responsible for the performance or safety of the customer installed thermal oil system. To ensure proper operation, refer to the *Specifications and Dimensions* section for the Btu input of equivalent steam models. Thermal oil systems that do not deliver appropriate Btus will dry slower. For solenoid valve wiring connections, refer to the Wiring Diagram supplied with tumble dryer.

## 120 Series Tumble Dryers

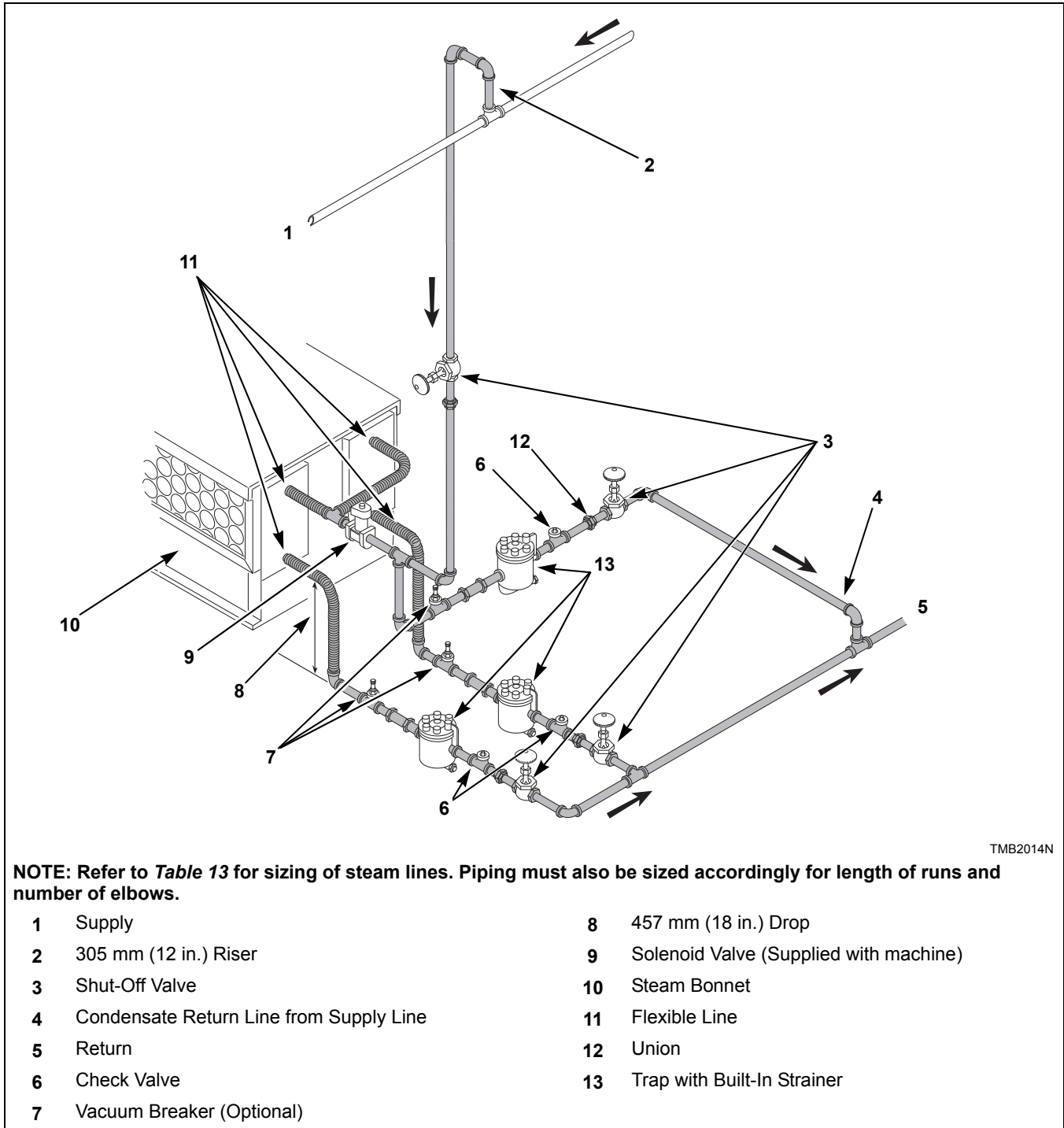

TMB2014N

Figure 19

Steam Pressure bar (PSI)	Minimum Supply Pipe Diameter	Steam Trap Size* Kilograms Condensate/Hour (Pounds Condensate/Hour)
5.3-6.9 (80-100)	1 in. NPT	156 (345)

\* Based on maximum bar.

Table 13

# 170 and 200 Series Tumble Dryers

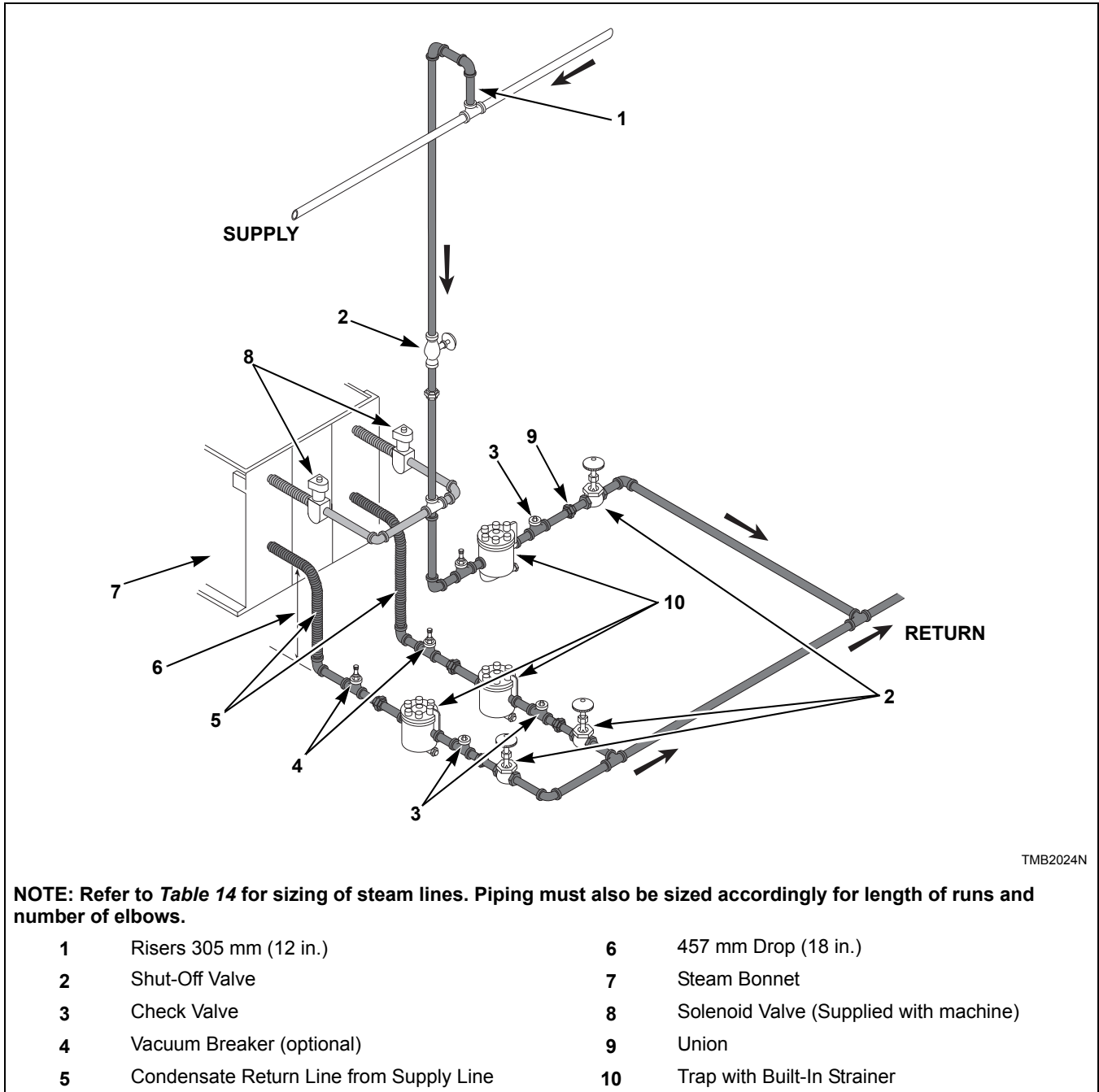



Figure 20

Steam Pressure bar (PSI)	Minimum Supply Pipe Diameter	Steam Trap Size * Kilograms Condensate/Hour (Pounds Condensate/Hour)
5.3-6.9 (80-100)	1-1/4 in. NPT	235 (517)

\* Based on maximum bar.

Table 14

# Operating Instructions

	<b>WARNING</b>
<p>To reduce the risk of fire:</p> <ul style="list-style-type: none"><li>• <b>DO NOT DRY</b> articles containing foam rubber or similarly textured rubberlike materials.</li><li>• <b>DO NOT DRY</b> plastics, anything containing wax or chemicals such as mops and cleaning cloths, or anything dry-cleaned at home with a dry-cleaning solvent.</li><li>• <b>DO NOT TUMBLE</b> fiberglass curtains and draperies unless the label says it can be done. If they are dried, wipe out the cylinder with a damp cloth to remove particles of fiberglass.</li></ul> <p style="text-align: right;">W076</p>	
<p>To reduce the risk of serious injury, allow cylinder to stop before cleaning lint screen.</p> <p style="text-align: right;">W412</p>	

## Emergency Stop Button On CE Models

All CE approved tumble dryers are factory equipped with an emergency stop button located on the front panel. Refer to *Figure 21*.

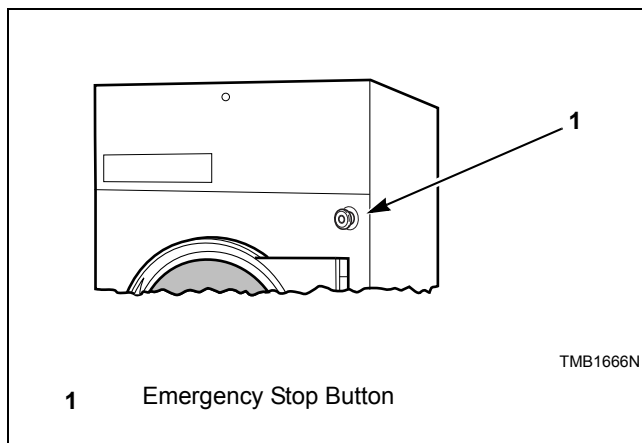



Figure 21

To operate emergency stop button:

- a. Press red emergency stop button to stop all action.
- b. To restart machine, pull red emergency stop button out and press START pad or button.

**NOTE: Activation of the emergency stop button stops all machine control circuit functions, but DOES NOT remove all electrical power from machine.**

	<b>WARNING</b>
<p>To reduce the risk of fire, electric shock, or injury to persons, read the <b>IMPORTANT SAFETY INSTRUCTIONS</b> before operating this appliance.</p> <p style="text-align: right;">W727</p>	

**IMPORTANT:** This appliance shall not be used to dry off solvents or dry cleaning fluids.

## Operating Instructions

### Step 1: Clean Lint Screen/Compartment

Remove any accumulated lint from the lint screen and compartment. Close panel tightly against tumble dryer frame and lock panel securely, if applicable.

**IMPORTANT:** Clean lint screen and lint compartment daily. Failure to clean the lint screen daily will result in higher than normal temperatures that may damage laundry.

	<b>WARNING</b>
<p>To reduce the risk of fire and risk of lint collecting in exhaust duct, do not operate tumbler without lint filter in place.</p> <p style="text-align: right;">W772</p>	

## Step 2: Load Laundry

Open loading door and load cylinder with laundry. Maximum drying load for 120 models is 54.4 kg (120 pounds), for 170 models is 77.1 kg (170 pounds) and for 200 models is 90.7 kg (200 pounds). DO NOT OVERLOAD.

**NOTE: Overloading causes slow drying and wrinkling.**

Close loading door. Tumble dryer will not operate with the door open.

## Step 3: Determine Control Type and Temperature Setting

Refer to the various controls and follow the instructions for the appropriate control type.

The type of fabric being dried will determine the temperature setting. Consult the fabric care label or fabric manufacturer to determine proper temperature setting.

**IMPORTANT: Always follow the fabric care instructions supplied by the garment manufacturer.**

## Step 4: Remove Laundry

When the cycle is complete, open door and remove the laundry.

## Operating Instructions

### Control Instructions

#### RQ Control Suffix

#### Dual Digital Timer Control

1. Select HIGH, MED, LOW or NO HEAT by turning the temperature knob.

HIGH Temperature 88°C (190°F)

MED Temperature 77°C (170°F)

LOW Temperature 49°C (120°F)

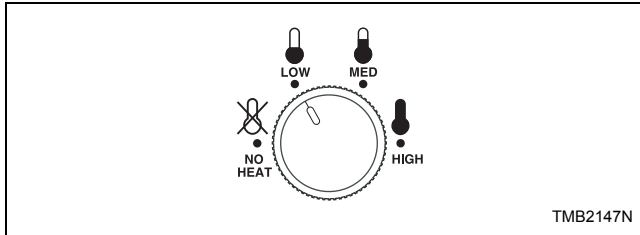

Figure 22

2. Set the HEAT TIME for the number of minutes (from 0 - 60) desired.

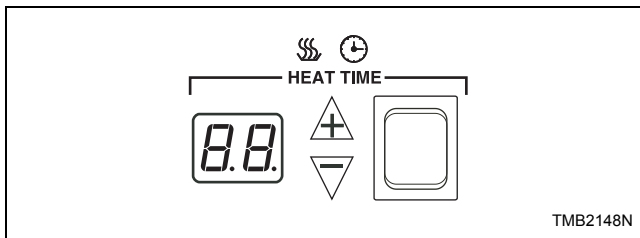

Figure 23

3. Set the COOL DOWN TIME for the number of minutes (from 0 - 15) desired.

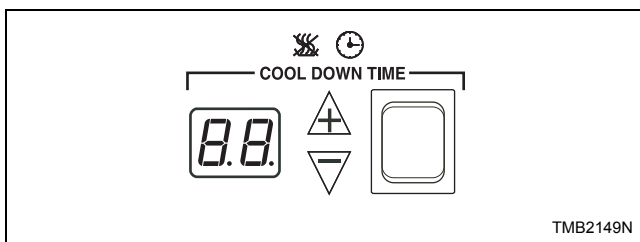

Figure 24

4. Select reversing or nonreversing cylinder rotation setting, if applicable.

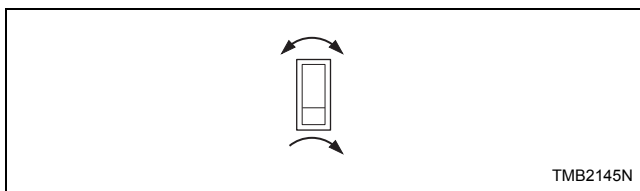

Figure 25

5. Press and release START button to start tumble dryer. Display will show minutes remaining before end of cycle.

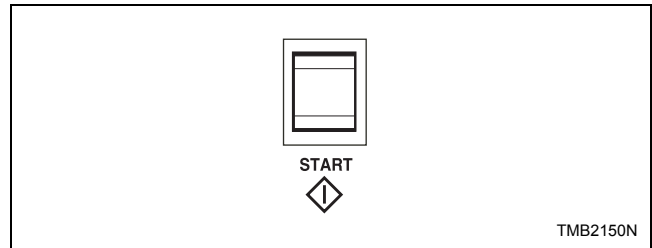

Figure 26

**NOTE:** One touch drying is available for repetitive loads. If the START button is pressed while the machine is in Idle Mode, when the display is dark, the tumble dryer will repeat the last drying cycle. If the cycle time is adjusted before the cycle is started, the time displayed when the start button was pressed will be used for future cycles.

**IMPORTANT:** To stop the tumble dryer at any time during the cycle, OPEN DOOR. If the loading door or lint panel door is opened during the cycle, the heating system will shut off and the motor will stop. To restart the cycle, both doors must be closed and the START button must be pressed in.

If the load cools to 32°C (90°F) before cool down time expires, the control will flash "Lr" (load ready) in the heat time display. If the door is not opened, the tumble dryer completes the selected cool down time. If the door is opened after reaching "Lr" temperature, the cycle will be terminated.

**NOTE:** If display shows an error code, refer to *Error Codes* section.

6. When the cycle is complete, open door and remove the laundry.

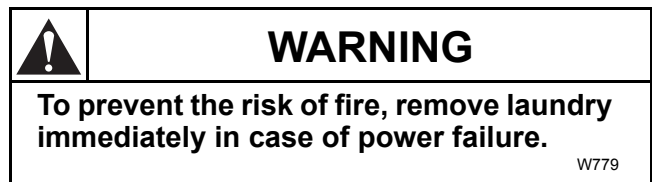

**NOTE:** This machine includes an anti-wrinkle/extended tumble feature. After the drying cycle is complete, the cylinder will tumble without heat every few minutes. The intermittent tumbling will continue for one hour or until the door is opened. Anti-wrinkle feature will tumble the load without heat for 30 seconds every 2 minutes for 1 hour OR until the loading door is opened.

**Error Codes**

<b>Display</b>	<b>Definition</b>	<b>Corrective Action</b>
<b>OP</b>	Open thermistor error	<ul style="list-style-type: none"> <li>• Check thermistor. Replace if inoperative.</li> <li>• Check wiring diagram between control and thermistor. Refer to wiring diagram for proper wiring.</li> <li>• Check control. Replace if inoperative.</li> </ul>
<b>SH</b>	Shorted thermistor error	<ul style="list-style-type: none"> <li>• Check thermistor. Replace if inoperative.</li> <li>• Check wiring between control and thermistor. Refer to wiring diagram for proper wiring.</li> <li>• Check control. Replace if inoperative.</li> </ul>
<b>AF - 1</b>	Airflow switch closed when cycle started	<ul style="list-style-type: none"> <li>• Check airflow switch. Replace if inoperative.</li> </ul>
<b>AF - 2</b>	Airflow switch failed to close after cycle started	<ul style="list-style-type: none"> <li>• Check airflow switch. Replace if inoperative.</li> </ul>
<b>AF (Flashing)</b>	Bouncing Airflow Switch	<ul style="list-style-type: none"> <li>• Check airflow switch to ensure that it is properly aligned and securely mounted in the mounting bracket.</li> <li>• Make sure airflow switch can open and close freely.</li> <li>• Check installation and make sure there is adequate airflow.</li> <li>• Make sure exhaust is not blocked.</li> <li>• Clean the lint screen.</li> <li>• Replace airflow switch if inoperative.</li> </ul>
<b>AF (Solid)</b>	Airflow Switch Closed when Resuming Cycle	<ul style="list-style-type: none"> <li>• Allow up to 20 seconds for this condition to clear.</li> <li>• Check if airflow switch opens at end of cycle.</li> <li>• Replace airflow switch if inoperative.</li> </ul>

## Operating Instructions

### Electronic OPL Micro Control

#### L and P Models with RM Control Suffix

1. To use an Automatic Cycle, press an ON/ SELECT pad. Select HIGH, MEDIUM, MED LOW, LOW or NO HEAT for items that should not be dried with heat. A light to the left of the selected pad lights up.

HIGH Temperature 82°C (180°F)  
 MEDIUM Temperature 71°C (160°F)  
 MED LOW Temperature 60°C (140°F)  
 LOW Temperature 49°C (120°F)

To use a Time Dry or Custom Cycle, refer to the *Programming Manual*.

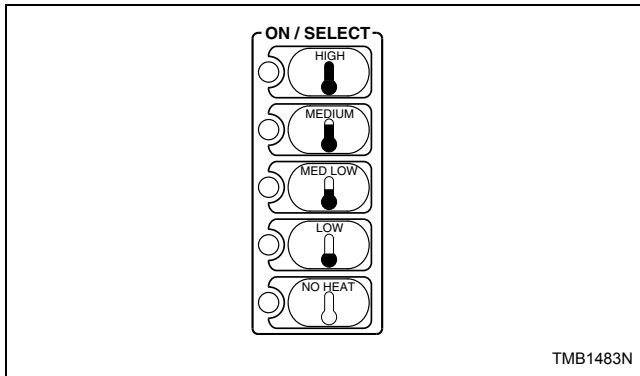

Figure 27

**NOTE: Do not press directly on lights or the center of pad. For proper selection, press on pad slightly to the right of center. Refer to Figure 28.**

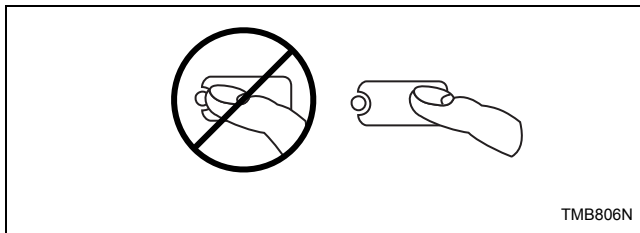

Figure 28

2. Select REVERSING or NONREVERSING cylinder rotation setting.

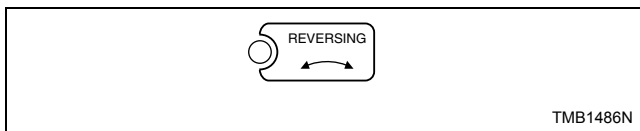

Figure 29

3. Press START pad to start tumble dryer.

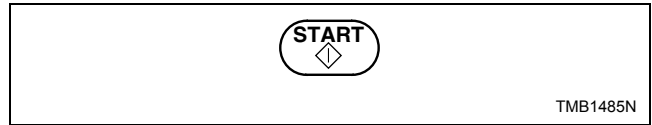

Figure 30

**NOTE: All pads can be pressed in any sequence without damaging control or tumble dryer. To stop the tumble dryer at any time, open the door or press STOP/RESET.**

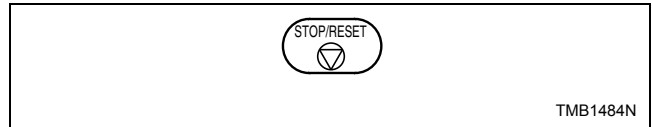

Figure 31

**NOTE: The window display will flash. Press STOP/RESET twice (within three seconds) to end the cycle and reset the control to idle status. To restart the tumble dryer, CLOSE door and press START pad.**

**IMPORTANT: If the loading door or lint panel door is opened during the cycle, the heating system will shut off and the motor will stop. To restart the cycle, both doors must be closed and START pad must be pressed.**

4. When the cycle is complete, open door and remove the laundry.

	<b>WARNING</b>
<b>To prevent the risk of fire, remove laundry immediately in case of power failure.</b>	
W779	

**NOTE: This machine includes an anti-wrinkle/extended tumble feature. After the drying cycle is complete, the cylinder will tumble without heat every few minutes. The intermittent tumbling will continue for one hour or until the door is opened.**



**G and K Models with RM Control Suffix**

- To use an Automatic Cycle, press a TEMPERATURE pad. Select HIGH, MED, LOW, DELICATE or NO HEAT for items that should not be dried with heat. A light to the left of the selected pad lights up.

HIGH Temperature 82°C (180°F)  
 MEDIUM Temperature 71°C (160°F)  
 LOW Temperature 60°C (140°F)  
 DELICATE Temperature 49°C (120°F)

To use a Time Dry or Custom Cycle, refer to the **Programming Manual**.

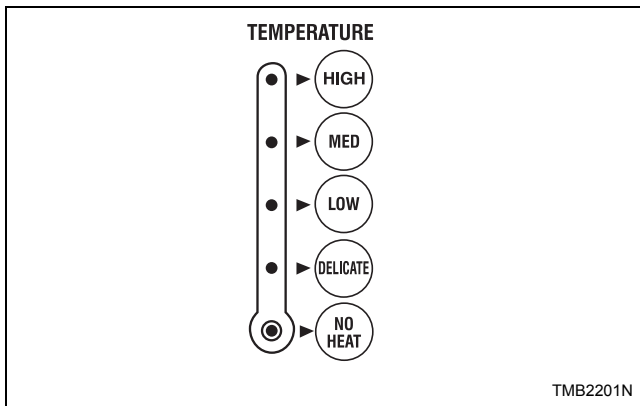

Figure 32

- Select REVERSING or NONREVERSING cylinder rotation setting.

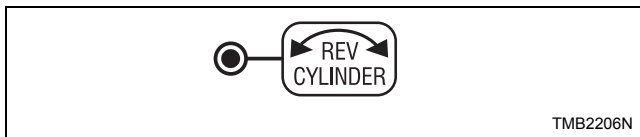

Figure 33

- Press START pad to start tumble dryer.

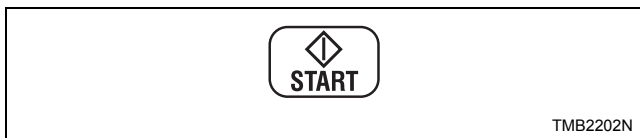

Figure 34

**NOTE: All pads can be pressed in any sequence without damaging control or tumble dryer. To stop the tumble dryer at any time, open the door or press STOP.**



Figure 35

**NOTE: The window display will flash. Press STOP twice (within 3 seconds) to end the cycle and reset the control to idle status. To restart the tumble dryer, CLOSE door and press START pad.**

**IMPORTANT: If the loading door or lint panel door is opened during the cycle, the heating system will shut off and the motor will stop. To restart the cycle, both doors must be closed and the PUSH TO START button must be pressed in.**

- When the cycle is complete, open door and remove the laundry.

	<b>WARNING</b>
<b>To prevent the risk of fire, remove laundry immediately in case of power failure.</b>	
<small>W779</small>	

**NOTE: This machine includes an anti-wrinkle/extended tumble feature. After the drying cycle is complete, the cylinder will tumble without heat every few minutes. The intermittent tumbling will continue for one hour or until the door is opened.**

**Reversing Operation**

Tumble dryers with the reversing option prevent the tangling of large pieces of laundry and minimize wrinkling. These tumble dryers are equipped with a second motor and additional controls which reverse the rotation direction of the cylinder.

**Reverse Control Switch**

An “on-off” switch for manual timer models, or a touch pad for OPL Micro models is placed in the control panel area so the operator can select the reversing or nonreversing operation. In nonreversing mode, the cylinder will always turn clockwise (as viewed from the front of the tumble dryer). If the cylinder is turning counterclockwise when switched to nonreversing, it will continue for a few seconds and then start up in the proper direction.

**IMPORTANT: After any electrical maintenance is done, make sure that the blower motor is turning counterclockwise as viewed from the front. Then set the reverse control switch to “nonreversing” and note that the cylinder turns constantly clockwise as viewed from the front of the tumble dryer. If not, interchange L1 and L2 service leads to reverse the drive motor.**

## Operating Instructions

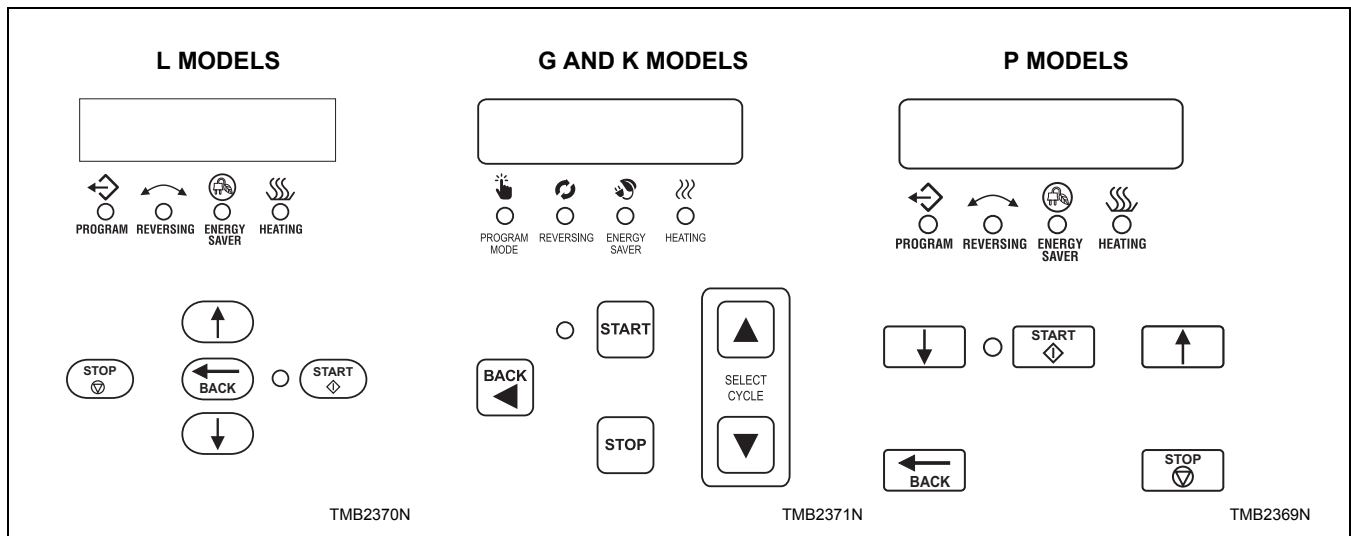

Figure 36

### LED OPL Control

#### RE Control Suffix

1. Press the Up (↑) or Down (↓) keypad to change cycles.

To customize a cycle, refer to the *Programming Manual*.

2. Press Start (◇/↔) to start selected cycle.

**IMPORTANT:** If the loading door or lint panel door is opened during the cycle, the heating system will shut off and the motor will stop. To restart the cycle, both doors must be closed and the Start (◇/↔) pad must be pressed.

3. When the cycle is complete, open door and remove laundry.

	<b>WARNING</b>
<b>To prevent the risk of fire, remove laundry immediately in case of power failure.</b>	
<small>W779</small>	

**NOTE:** This machine includes an anti-wrinkle/extended tumble feature. After the drying cycle is complete, the cylinder will tumble without heat every few minutes. The intermittent tumbling will continue for one hour or until the door is opened. After an hour the machine enters delayed tumble and will tumble for two minutes every hour for up to 18 hours or until the door is opened.

## Ignition Control Operation for Non-CE Models

### Power Up

When power is applied to the ignition control, the control will begin the ignition sequence within 1 – 3 seconds prepurge waiting time.

### Ignition Sequence

The control begins the ignition sequence after prepurge by powering the ignitor and opening the gas valve. The ignitor will remain on either until a flame is sensed or until a maximum of ten (10) seconds (10 +0/-4 sec) has elapsed. If a flame is established and lost during the 10 second period, the ignitor will be powered up again in an attempt to re-ignite the gas.

If no flame is detected within the ten (10) second ignition sequence, the control will terminate power to the gas valves, ignitor, and enter lockout within 5 seconds.

### Normal Operation

Once a flame has been established, the spark ignitor will stop sparking and the control will continually monitor all inputs. If the controller senses a loss of flame after flame is established, the gas valve will remain energized and sparking will commence within one second of the flame loss. If flame reattempt fails, lockout will occur within 11 seconds of initial flame loss.

### Termination of Flame

Normal flame termination occurs when the thermostat has been satisfied, meaning there is no immediate need for more heat. The thermostat will disconnect power from the ignition control, which will cause the gas valve to close and the flame to go out. After a short period of time, not less than 1 second, the thermostat will cool down and close causing power to be reapplied to the ignition control. When this occurs, the control must complete the same prepurge and ignition sequence specified above.

### Control Lockout

When the control locks out, the gas valve will be closed and all requests for heat will be ignored. The lockout mode may only be discontinued by interrupting power to the control or cycling the thermostat. After this occurs, the control will restart with its normal power up and ignition sequence.

### Low Voltage Detection

The control will have capability for detection of a low voltage input condition. If input voltage on power up is below 19.0VAC +0.8VAC/-0.5VAC, the control will disable output to gas valve control relay. If input voltage rises above 19.8VAC for at least three (3) seconds, the control will then re-enable function of the gas valve control relay and ignition sequence may begin. On power up, the control function must always be disabled if greater than 19.8VAC.

# Ignition Control Operation for CE Models

## Power Up

After 24VAC is applied to the ignition control pins 24V and GND, the Diagnostic LED on the ignition control will turn orange/yellow. If a fault is detected the ignition control will enter Lockout Mode. If no faults are detected, the Diagnostic LED will turn Green and the ignition control will enter Standby Mode.

## Standby Mode

While in Standby Mode, the ignition control will continually monitor the system for faults. Once 24VAC is applied to terminals TH and GND on the control, the ignition control will enter Start Up Mode.

## Start Up Mode

During Start Up Mode, the ignition control will monitor the system for faults and begin the ignition sequence. If no faults are present, the ignition control will begin the ignition sequence by entering an 18 second waiting period. During this time the Green LED on the ignition control will switch between Red and Green, before maintaining a Green color.

After the waiting period, the ignition control will turn on the igniter and gas valve. The igniter will remain on until a flame is sensed, or up to 10 seconds.

Once a flame has been sensed the ignition control will stop sparking, the gas valve will remain on and ignition control will enter Run Mode.

If a flame is not sensed, the ignition control will then begin two additional retrials for ignition. The ignition control will re-enter the 18 seconds waiting period before the ignition control makes another attempt at ignition. If the three attempts at ignition fail, the ignition control will enter Lockout Mode.

## Run Mode

While in Run Mode the ignition control leaves the gas valve on, monitors the flame signal, and leaves the igniter off.

If a flame signal is lost during Run Mode, one additional retrial for ignition will take place within one second. The ignition control will restore the spark for approximately 10 seconds. If the ignition re-attempt fails, the ignition control will enter Lockout Mode.

The ignition control will remain in Run Mode until 24VAC is removed from terminals TH and GND on the control.

## Termination of Flame

The flame will go out when power is removed from ignition control. The ignition control will turn off the gas valve and enter Standby Mode.

## Lockout Mode

When Lockout Mode is entered, the ignition control will remove power to the gas valve, the igniter will turn off, the Lockout/Reset Light will turn on, and the Diagnostic LED will display the appropriate Error Code.

## Lockout Manual Reset

Lockout Mode is cleared by pressing an external reset switch for three seconds. The ignition control will clear all error codes and enter Standby Mode. During Lockout Manual Reset, the Diagnostic LED on the ignition control flashes red and orange, and the Reset Light remains on until the ignition control is reset. After the Reset Light turns off, stop pressing the switch. Holding the reset for three seconds after lockout has been cleared will cause a fault and result in entering Lockout Mode again.

## System Tests

The following system tests are performed during normal operation. System tests are performed at a minimum of every 24 hours.

## Low Voltage Detection

If the voltage between terminals TH and GND on the control is below 18.75VAC +/- 0.75VAC for more than 3 seconds the ignition control will turn off the gas valve and will not attempt to spark. The Diagnostic LED will display Error Code 5. The ignition control will not enter Lockout Mode if a low voltage condition is detected, but will enter Standby Mode and wait for the low voltage condition to be cleared.

If the voltage between terminals TH and GND on the control rises above 19.75VAC +/- 0.1VAC for at least 3 seconds, the ignition control will then enter Start Up Mode.

Low Voltage Detection test is disabled during Run Mode.

## Gas Valve

The ignition control verifies that the gas valve is connected. Failure of this test results in the ignition control entering Lockout Mode with the Diagnostic LED displaying Error Code 2.

### Flame Probe Tests

#### Unexpected Presence of Flame

The Unexpected Presence of Flame test is performed when no flame is expected. Failure of this test results in the ignition control entering Lockout Mode with the Diagnostic LED displaying Error Code 3.

#### Flame Monitoring

During the Flame Monitoring test, the flame is checked to ensure the gas is being burned when the gas valve is on. Failure of this test will result in the ignition control entering Lockout Mode with the Diagnostic LED displaying Error Code 3.

### Diagnostic LED (DGN LED)/Error Codes

The Diagnostic LED or DGN LED is located by the power connector on the ignition control. Refer to *Figure 37*. The Diagnostic LED will indicate the status of the ignition control. Refer to *Table 15*.

LED Color	Description
Orange-Yellow	Initialization
Green	Standby/Normal Operation
Red	Fault Indication Code

Table 15

The Diagnostic LED will flash error codes one half second on and one half second off. Error codes are separated by a one second pause before the code is repeated.

Error Code	DGN LED status	Fault Type
1	Red	Ignition Control Internal Failure
2	2 Red Flashes	Gas Valve Not Connected
3	3 Red Flashes	Ignition/Flame Sense Failure
4	4 Red Flashes	Reset Switch is Shorted
5	Slow Red and Green Flashes	Low Voltage Detection
6	Fast Red and Orange Flashes	Ignition Control is in Reset Delay

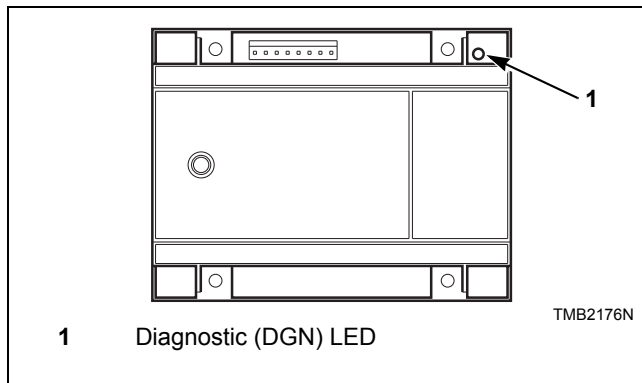



Figure 37

# Adjustments

	<b>WARNING</b>
<p>To reduce the risk of electric shock, fire, explosion, serious injury or death:</p> <ul style="list-style-type: none"><li>• Disconnect electric power to the tumble dryer before servicing.</li><li>• Close gas shut-off valve to gas tumble dryer before servicing.</li><li>• Close steam valve to steam tumble dryer before servicing.</li><li>• Never start the tumble dryer with any guards/panels removed.</li><li>• Whenever ground wires are removed during servicing, these ground wires must be reconnected to ensure that the tumble dryer is properly grounded.</li></ul>	
<small>W002R1</small>	

## Gas Burner Air Shutter

**NOTE:** Air inlet shutters on the burner must be adjusted so sufficient air is metered into the system for proper combustion and maximum efficiency. Before adjusting the inlet shutters be sure that all lint is removed from lint compartments and lint screen.

Air shutter adjustments will vary from location to location and will depend on the vent system, number of units installed, make-up air and line gas pressure. Opening the shutter increases the amount of primary air supplied to the burner while closing the shutter decreases the primary air supply. Adjust air shutter as follows:

Refer to *Figure 38*.

1. Remove the upper access panel and burner inspection hole plate.
2. Start the tumble dryer and check the flame pattern. If the flame pattern is straight up, insufficient air is flowing through the tumble dryer. A flame pattern that flares to the right and left indicates no air is flowing through the tumble dryer. Correct air and gas mixture is indicated if the flame pattern is primarily blue, with small yellow tips, and bends to the right of the heater section. Too little air is indicated if the flame is yellow, lazy and smokey.
3. To adjust the air shutter, loosen air inlet shutter adjusting screw.
4. Open or close air shutter as necessary to obtain proper flame intensity.

5. After air shutter is adjusted for proper flame, tighten air shutter adjusting screw securely.

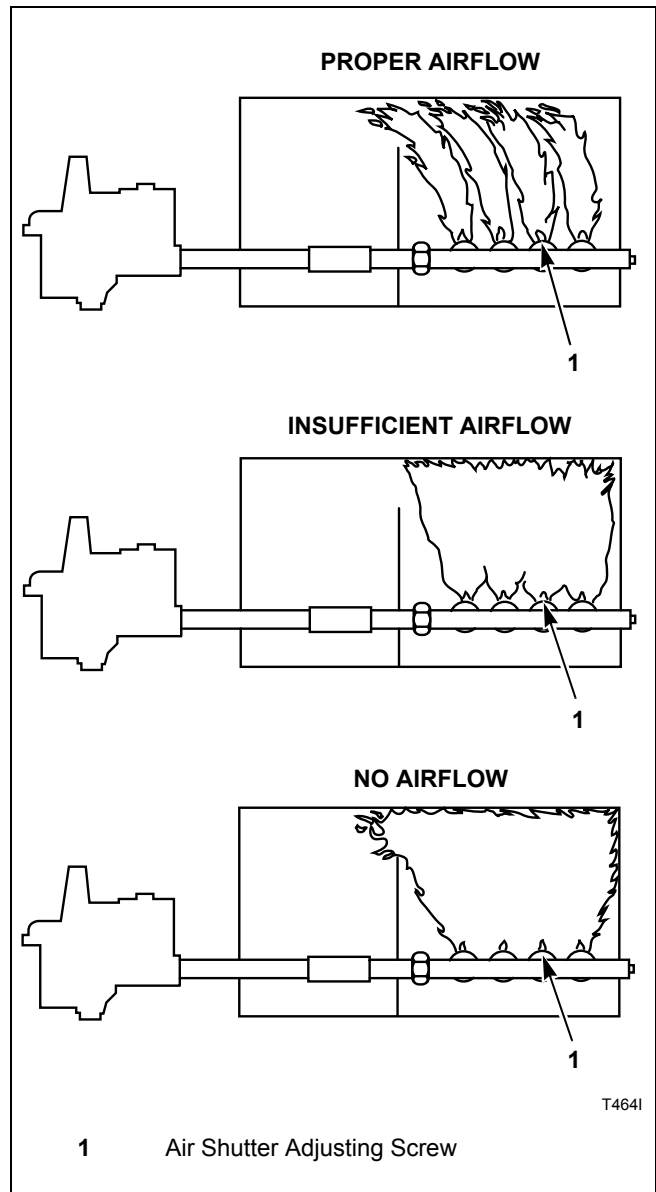



Figure 38

## Airflow Switch

The airflow switch is set at the factory for proper operation. No adjustment necessary.

The airflow switch operation may be affected by shipping tape still in place, lack of make-up air, or an obstruction in the exhaust duct. These should be checked and the required corrective action taken.

	<b>WARNING</b>
<p><b>The tumble dryer must not be operated if the airflow switch does not operate properly. Faulty airflow switch operation may cause an explosive gas mixture to collect in the tumble dryer.</b></p>	
W072R1	

**IMPORTANT:** Airflow switch vane must remain closed during operation. If it opens and closes during the drying cycle, this indicates insufficient airflow through the tumble dryer. If switch remains open, or pops open and closed during the cycle, the heating system will shut off. The cylinder and fan will continue to operate even though the airflow switch is indicating insufficient airflow.

**NOTE:** To properly mount the airflow switch bracket, or in case of a load not drying, the airflow switch bracket may need to be checked for proper alignment. Be sure the locator pins are securely in their respective holes before tightening the bracket mounting screws. This will assure proper alignment of the airflow switch arm in the channel of the airflow switch bracket and prevent binding of the arm.

### Loading Door Switch

Loading door switch is factory preset, no field adjustment is necessary.

### Loading Door Catch (120 and 170 Series Models)

The door catch must be adjusted to have sufficient tension to hold loading door closed against force of load tumbling against it. Proper adjustment is when 0.48-1.03 bar (7-15 pounds) pull is required to open door.

If adjustment is required, refer to *Figure 39* and proceed as follows:

To adjust, open door, loosen acorn nut and turn door strike screw in or out as required. Tighten acorn nut.

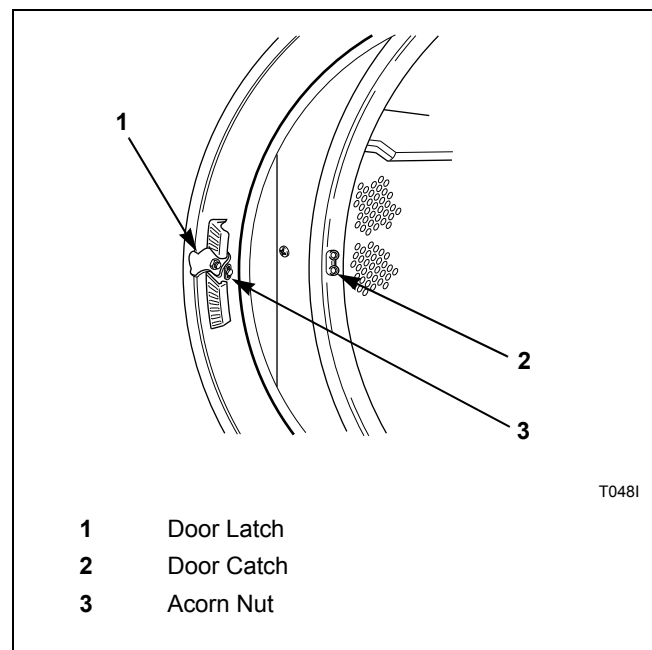

Figure 39

## Adjustments

### Loading Door Strike (200 Series Models)

The loading door strike must be adjusted to have sufficient tension to hold loading door closed against force of load tumbling against it. Proper adjustment is when 8-15 pounds (35.6-66.7 N) pull is required to open door.

If adjustment is required, refer to *Figure 40* and proceed as follows:

To adjust, open door, loosen adjustment screws and position strike for desired magnet engagement. Retighten screws.

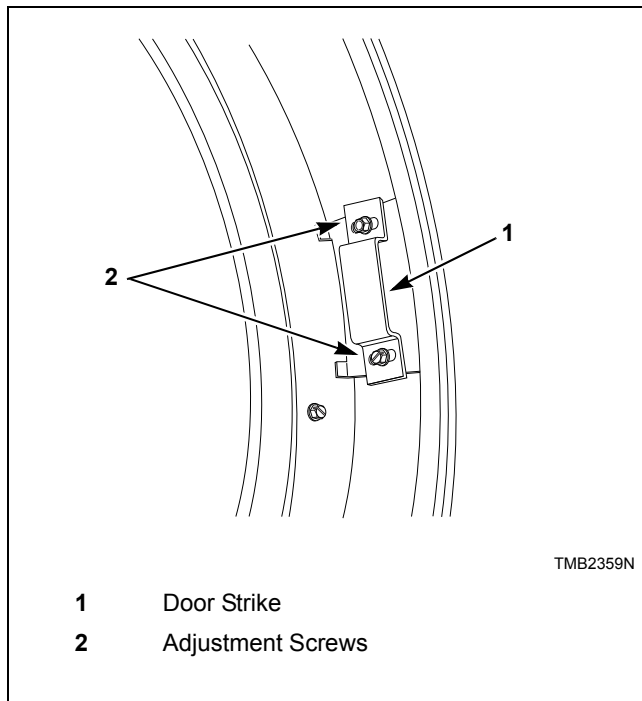

Figure 40

### Belt Drive

The drive assemblies consist of motors, belts, eyebolts and a step pulley.

The pulley diameters are sized to produce a cylinder speed of 37-39 RPM for 120 series models or 29-31 RPM for 170 and 200 series models.

The step pulley assembly is used for speed reduction as well as a means of adjusting belt tension. The pulley mounting plate is attached to the cabinet. The frame mounting plate has vertically slotted holes allowing up and down movement of the step pulley mounting plate for belt adjustment.

Adjust the belt tension as follows:

1. Disconnect electrical power to the tumble dryer before attempting any adjustments to the drive assembly.
2. Loosen pulley mounting plate bolts.
3. Loosen the upper nut on the final drive eyebolt.
4. Rotate the lower nut of the final drive eyebolt clockwise until proper belt tension is achieved.
5. Rotate upper nut clockwise against the lower nut in order to lock it into place.
6. Tighten pulley mounting plate bolts. Recheck belt tension.
7. If necessary, adjust the drive motor belt tension eyebolt using a similar procedure.
8. Adjust blower belt tension on 120 series 50 Hertz tumble dryers and all 170 series tumble dryers using a similar procedure.

**NOTE: Proper tensions for new belts are measured with a Borroughs Belt Tension Gauge:**

	Drive Motor		Final Drive		Blower	
	Initial	After Run-in	Initial	After Run-in	Initial	After Run-in
120	60-70	45-55	70-80	55-65	60-70	50-55
170	60-70	45-55	70-80	55-65	75-80	60-65
200	60-70	45-55	70-80	55-65	65-70	55-60

Table 16

**Using a Browning Belt Tension Gauge, the motor belt deflection should be 0.31 inch at five pounds pressure, and final drive belt deflection should be 0.25 inch at five pounds pressure.**

Belts should not slip or make any noise when starting up under normal load.



# Maintenance

## Daily

1. Inspect the area surrounding tumble dryers, remove all combustible materials, including lint, before operating the machines.
2. Check cylinder for foreign objects to avoid damage to clothing and equipment.
3. Clean lint from lint compartment and screen to maintain proper airflow and avoid overheating.

	<b>WARNING</b>
<p><b>To reduce the risk of serious injury, do not open the lint panel while the tumble dryer is in operation. Before cleaning the lint screen, open tumble dryer door and allow cylinder to completely stop.</b></p>	
<small>W410R1</small>	

- a. Open the lint panel.
  - b. Remove all accumulated lint in the lint compartment area. Lightly brush any lint that may be left on the lint screen.
  - c. Be sure the lint screen is not torn.
  - d. The lint screen is designed to completely cover the entire opening in the lint screen panel. Be sure that it does so.
  - e. Wipe lint off of the thermistor. Refer to *Figure 41*.
  - f. Replace the lint compartment panel on the tumble dryer ensuring a tight fit, and lock if applicable.
4. At end of day, clean the machine's top, front and side panels with mild detergent. Rinse with clean water. **DO NOT** use products that contain alcohol on the control panel.

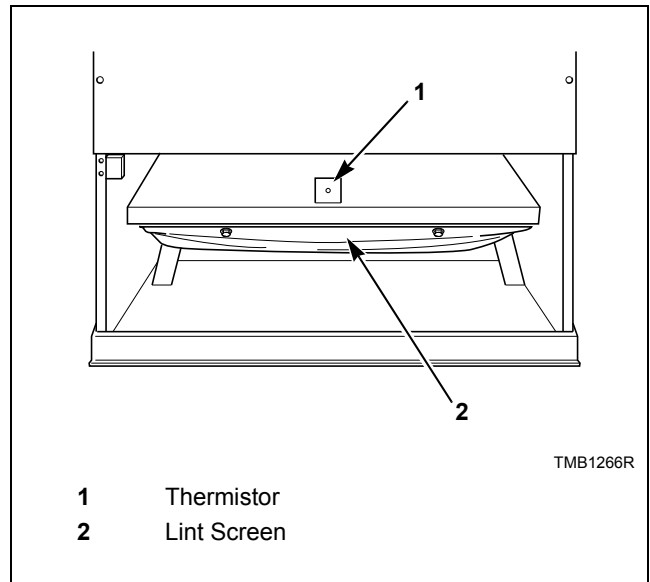

Figure 41

## Maintenance

### Monthly

1. Remove lint and debris from inside exhaust duct to maintain proper airflow and avoid overheating.
  - a. Remove external duct and duct access covers, if present.
  - b. Clean inside of duct with a vacuum.
  - c. Clean dampers and make sure they operate freely.
2. Ensure even lint distribution over lint screen.
3. Carefully wipe any accumulated lint off the cabinet high limit thermostat and thermistor, including perforated cover.
4. Clean lint and debris buildup from blower to maintain proper airflow.

### Quarterly

1. Use a vacuum to clean air vents on drive motors.
2. Use a vacuum to clean lint from rear limit thermostat cover.
3. Check and clean steam coils, if applicable.
4. Check flow of combustion and ventilation air.
5. Check belt tension and condition. Replace worn or cracked belts.

### Bi-Annually

1. Check mounting hardware for any loose nuts, bolts or screws.
2. Check gas connections for leakage.
3. Check for loose electrical connections.
4. Check steam connections for looseness and leakage.
5. Remove all front panels and vacuum, including coin drop mechanisms.
6. Check cylinder and front panel seals.
7. Inspect cabinet and inner panels for any damage, replace or repair as needed.
8. Clean burner tubes and orifice area of any lint buildup.

### Annually

1. Remove burner tubes and clean using water and a brush.

## Fire Suppression System Maintenance Test

To ensure proper operation, the fire suppression system must be tested every three months. If the system test does not perform as indicated:

1. Discontinue use of the tumble dryer.
2. Refer to *Troubleshooting Manual* or contact a qualified service person.
3. Restore the fire suppression system to proper working order before using tumble dryer.

Create a maintenance record with a check box for pass, the date and a signature. Store this record in an area where it will not be damaged, but is easily accessible to person performing tests.

**NOTE: Failure to maintain the fire suppression system will void the tumble dryer warranty.**

**NOTE: The auxiliary output is activated during the fire suppression system maintenance test sequence. Consider this fact prior to testing the system every three months. (Example – If the external system uses the auxiliary output to call the fire department, inform the fire department before and after the fire suppression system maintenance test.)**

**IMPORTANT: For Electric Models only – Whenever the machine has been internally sprayed with water, the heating elements must be completely dry before you run the machine with heat. To fully dry the heating elements, run the machine WITHOUT HEAT for a minimum of sixty (60) minutes before resuming normal operation.**

	<b>CAUTION</b>
<b>Clean up any water spilled during testing to avoid personal injury.</b>	
W487	

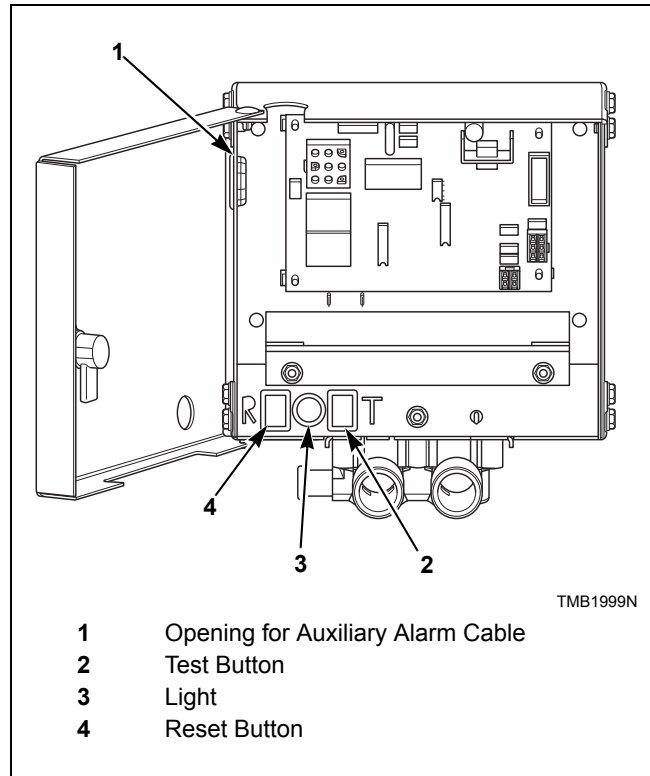

Figure 42

To perform the fire suppression system maintenance test:

1. If the auxiliary alarm output is connected to a separate alarm system, disconnect prior to performing the fire suppression system maintenance test.
2. Remove any lint from the lint compartment.
3. Ensure temperature sensors are free of lint.
4. Place a load of dry towels in the tumble dryer. Refer to *Table 17* for proper load size. Ensure the cylinder baffles are to the left and right of the spray manifold located at the center top of the cylinder.
5. Unlock the fire suppression system control box.
6. Press and hold the test button, verify the light is on, this should take approximately five seconds. Refer to *Figure 42*. After a one-second pause water should begin to spray into the cylinder.
7. After 15 seconds of water spray, press and hold the reset button until water spray is off and light is off. This should take approximately one second. Refer to *Figure 42* and *Figure 43*.

## Maintenance

- Immediately remove and weigh the load. Refer to *Table 17* for acceptable weight range. If less than minimum pounds indicated in *Table 17*, the fire suppression system has failed the maintenance test. Refer to the *Troubleshooting section*.

**IMPORTANT: If the fire suppression system failed the maintenance test, DO NOT operate the tumble dryer.**

	Dry Weight		Wet Weight		Minimum Weight	
	kg	lbs.	kg	lbs.	kg	lbs.
120	27	60	34-36	75-79	32	70
170	36	80	43-45	95-99	41	90
200	45	100	52-54	115-119	50	110

Table 17

- Clean up any water on the floor.
- Electric Models Only:** Run machine WITHOUT HEAT for a **minimum** of 60 minutes before continuing with steps 11-14.
- Lock the fire suppression system control box.
- If the separate alarm option is being used, reconnect the auxiliary alarm output.
- Start the tumble dryer to dry the test load.
- On maintenance record, check box if fire suppression system passed the test, date and sign record.

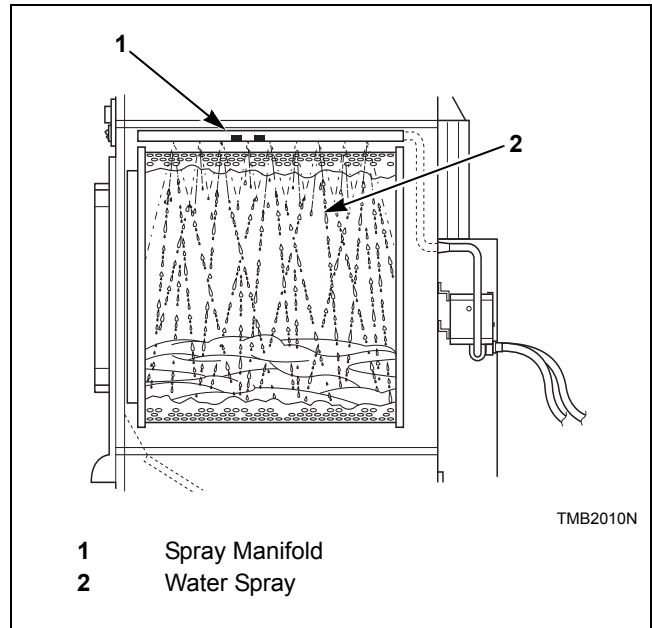

Figure 43

# Before You Call for Service

Won't Start	Won't Heat	Clothes Not Dry	Possible Reason – Corrective Actions
•			Insert correct coin(s) or valid card if applicable.
•			Close the loading door tightly.
•			Close lint panel tightly.
•			Press the PUSH-TO-START or START pad/button.
•			Be sure power cord is plugged all the way into the electrical outlet.
•			Drying timer is in OFF position.
•			Check the main fuse and circuit breaker.
•			Check fuses located in the machine.
	•		Insufficient airflow.
	•		Gas shut-off valve in OFF position.
	•		Are controls properly set?
	•		Broken drive belt. Call the service person.
	•	•	Tumble Dryer is in Cool Down Mode.
	•	•	Lint screen clogged. Clean lint screen.
	•	•	Exhaust duct to outside is blocked. Clean out.

## Removing Tumble Dryer from Service

If the tumble dryer is to be removed from service, perform the following steps where applicable:

- Turn off electrical supply external to machine.
- Turn off electrical disconnect on machine.
- Turn off gas supply external to machine.
- Turn off manual gas shut-off valve on machine.
- Turn off steam supply external to machine.
- Remove all electric, gas and steam connections.

# Disposal of Unit

This appliance is marked according to the European directive 2002/96/EC on Waste Electrical and Electronic Equipment (WEEE).

This symbol on the product or on its packaging indicates that this product shall not be treated as household waste. Refer to *Figure 44*. Instead it shall be handed over to the applicable collection point for the recycling of electrical and electronic equipment. Ensuring this product is disposed of correctly will help prevent potential negative consequences for the environment and human health which could otherwise be caused by inappropriate waste handling of this product. The recycling of materials will help to conserve natural resources. For more detailed information about recycling of this product, please contact the local city office, household waste disposal service, or the source from which the product was purchased.

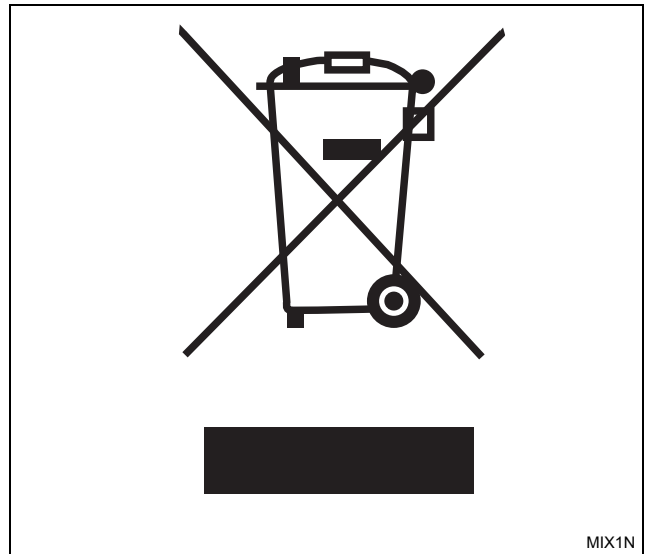

Figure 44